

EDF R&D



FLUID DYNAMICS, POWER GENERATION AND ENVIRONMENT DEPARTMENT
SINGLE PHASE THERMAL-HYDRAULICS GROUP

6, QUAI WATIER
F-78401 CHATOU CEDEX

TEL: 33 1 30 87 75 40
FAX: 33 1 30 87 79 16

DECEMBER 2021

code_saturne documentation

code_saturne version 7.1 practical user's guide

contact: saturne-support@edf.fr



EDF R&D	code_saturne version 7.1 practical user's guide	code_saturne documentation Page 1/71
---------	--	--

ABSTRACT

code_saturne is a system designed to solve the Navier-Stokes equations in the cases of 2D, 2D axisymmetric or 3D flows. Its main module is designed for the simulation of flows which may be steady or unsteady, laminar or turbulent, incompressible or potentially dilatible, isothermal or not. Scalars and turbulent fluctuations of scalars can be taken into account. The code includes specific modules, referred to as "specific physics", for the treatment of Lagrangian particle tracking, semi-transparent radiative transfer, gas combustion, pulverised coal combustion, electricity effects (Joule effect and electric arcs) and compressible flows. code_saturne relies on a finite volume discretisation and allows the use of various mesh types which may be hybrid (containing several kinds of elements) and may have structural non-conformities (hanging nodes).

The present document is a practical user's guide for code_saturne version 7.1. It is the result of the joint effort of all the members in the development team. It presents all the necessary elements to run a calculation with code_saturne version 7.1. It then lists all the variables of the code which may be useful for more advanced utilisation. The user subroutines of all the modules within the code are then documented. Eventually, for each key word and user-modifiable parameter in the code, their definition, allowed values, default values and conditions for use are given. These key words and parameters are grouped under headings based on their function. An alphabetical index list is also given at the end of the document for easier consultation.

code_saturne is free software; you can redistribute it and/or modify it under the terms of the GNU General Public License as published by the Free Software Foundation; either version 2 of the License, or (at your option) any later version. code_saturne is distributed in the hope that it will be useful, but WITHOUT ANY WARRANTY; without even the implied warranty of MERCHANTABILITY or FITNESS FOR A PARTICULAR PURPOSE. See the GNU General Public License for more details.

EDF R&D	code_saturne version 7.1 practical user's guide	code_saturne documentation Page 2/71
---------	--	--

TABLE OF CONTENTS

1	Introduction	7
2	Basic modelling setup	7
2.1	MANAGE BOUNDARY CONDITIONS	7
	2.1.1 CODING OF STANDARD BOUNDARY CONDITIONS	9
	2.1.2 CODING OF NON-STANDARD BOUNDARY CONDITIONS	11
	2.1.3 CHECKING OF THE BOUNDARY CONDITIONS	14
	2.1.4 SORTING OF THE BOUNDARY FACES	14
2.2	USER SOURCE TERMS	14
	2.2.1 IN NAVIER-STOKES	15
	2.2.2 FOR k AND ε	16
	2.2.3 FOR R_{ij} AND ε	16
	2.2.4 FOR φ AND \bar{f}	16
	2.2.5 FOR k AND ω	16
	2.2.6 FOR $\tilde{\nu}_t$	17
	2.2.7 FOR USER SCALARS	17
3	Advanced modelling setup	17
3.1	USE OF A SPECIFIC PHYSICS	17
3.2	PULVERISED COAL AND GAS COMBUSTION MODULE	22
	3.2.1 BOUNDARY CONDITIONS	24
	3.2.2 INITIALISATION OF THE OPTIONS OF THE VARIABLES	26
3.3	HEAVY FUEL OIL COMBUSTION MODULE	29
	3.3.1 INITIALISATION OF TRANSPORTED VARIABLES	29
	3.3.2 BOUNDARY CONDITIONS	29
3.4	RADIATIVE THERMAL TRANSFERS IN SEMI-TRANSPARENT GRAY MEDIA	30
	3.4.1 INITIALISATION OF THE RADIATION MAIN PARAMETERS	30
	3.4.2 RADIATIVE TRANSFERS BOUNDARY CONDITIONS	31
	3.4.3 ABSORPTION COEFFICIENT OF THE MEDIUM, BOUNDARY CONDITIONS FOR THE LUMINANCE AND CALCULATION OF THE NET RADIATIVE FLUX	33
3.5	CONJUGATE HEAT TRANSFER	34
	3.5.1 THERMAL MODULE IN A 1D WALL	34
	3.5.2 INTERNAL FLUID-THERMAL COUPLING	34
	3.5.3 FLUID-THERMAL COUPLING WITH SYRTHES	35
3.6	PARTICLE-TRACKING (LAGRANGIAN) MODULE	36
	3.6.1 GENERAL INFORMATION	36
	3.6.2 ACTIVATING THE PARTICLE-TRACKING MODULE	36
	3.6.3 BASIC GUIDELINES FOR STANDARD SIMULATIONS	36

3.6.4	PREScribing THE MAIN MODElling PARAMETERS	37
3.6.5	PREScribing PARTICle BOUNDARY CONDITIONS	38
3.6.6	ADVANCED PARTICle-TRACKING SET-UP	39
3.7	COMPRESSIBLE MODULE	40
3.7.1	INITIALISATION OF THE OPTIONS OF THE VARIABLES	40
3.7.2	MANAGEMENT OF THE BOUNDARY CONDITIONS	41
3.7.3	INITIALISATION OF THE VARIABLES	41
3.7.4	MANAGEMENT OF VARIABLE PHYSICAL PROPERTIES	42
3.8	MANAGEMENT OF THE ELECTRIC ARCS MODULE	42
3.8.1	ACTIVATING THE ELECTRIC ARCS MODULE	42
3.8.2	INITIALISATION OF THE VARIABLES	42
3.8.3	VARIABLE PHYSICAL PROPERTIES	42
3.8.4	BOUNDARY CONDITIONS	43
3.8.5	INITIALISATION OF THE VARIABLE OPTIONS	44
3.9	CODE_SATURNE-CODE_SATURNE COUPLING	44
3.10	FLUID-STRUCTURE EXTERNAL COUPLING	45
3.11	ALE MODULE	46
3.11.1	INITIALISATION OF THE OPTIONS	46
3.11.2	MESH VELOCITY BOUNDARY CONDITIONS	47
3.11.3	MODIFICATION OF THE MESH VISCOSITY	48
3.11.4	FLUID - STRUCTURE INTERNAL COUPLING	48
3.12	MANAGEMENT OF THE STRUCTURE PROPERTY	49
3.13	MANAGEMENT OF THE ATMOSPHERIC MODULE	49
3.13.1	DIRECTORY STRUCTURE	50
3.13.2	THE ATMOSPHERIC MESH FEATURES	50
3.13.3	ATMOSPHERIC FLOW MODEL AND STEADY/UNSTEADY ALGORITHM	50
3.13.4	PHYSICAL PROPERTIES	51
3.13.5	BOUNDARY AND INITIAL CONDITIONS	51
3.13.6	USER SUBROUTINES	53
3.13.7	PHYSICAL MODELS	53
3.13.8	ATMOSPHERIC MAIN VARIABLES	54
3.13.9	RECOMMENDATIONS	55
3.14	TURBOMACHINERY COMPUTATIONS	56
3.14.1	INTRODUCTION	56
3.14.2	MESHING RECCOMENDATIONS	56
3.14.3	TURBOMACHINERY DEDICATED POSTPROCESSING FUNCTIONS	57
3.14.4	DATA SETTING, KEYWORDS AND EXAMPLES	57

3.15	CAVITATION MODULE	57
4	Keyword list	62
4.1	INPUT-OUTPUT	62
	4.1.1 "CALCULATION" FILES	63
4.2	NUMERICAL OPTIONS	63
	4.2.1 CALCULATION MANAGEMENT	63
	4.2.2 SCALAR UNKNOWNNS	63
	4.2.3 DEFINITION OF THE EQUATIONS	63
	4.2.4 DEFINITION OF THE TIME ADVANCEMENT	63
	4.2.5 TURBULENCE	64
	4.2.6 TIME SCHEME	64
	4.2.7 GRADIENT RECONSTRUCTION	65
	4.2.8 SOLUTION OF THE LINEAR SYSTEMS	65
	4.2.9 CONVECTIVE SCHEME	65
	4.2.10 PRESSURE-CONTINUITY STEP	65
	4.2.11 ERROR ESTIMATORS FOR NAVIER-STOKES	65
	4.2.12 CALCULATION OF THE DISTANCE TO THE WALL	67
	4.2.13 OTHERS	67
4.3	NUMERICAL, PHYSICAL AND MODELLING PARAMETERS	67
	4.3.1 NUMERIC PARAMETERS	67
	4.3.2 PHYSICAL PARAMETERS	67
	4.3.3 PHYSICAL VARIABLES	67
4.4	ALE	68
4.5	THERMAL RADIATIVE TRANSFERS: GLOBAL SETTINGS	68
4.6	ELECTRIC MODULE (JOULE EFFECT AND ELECTRIC ARCS): SPECIFICITIES	68
5	Bibliography	69
	Index of the main variables and keywords	70

EDF R&D	code_saturne version 7.1 practical user's guide	code_saturne documentation Page 6/71
---------	--	--

EDF R&D	code_saturne version 7.1 practical user's guide	code_saturne documentation Page 7/71
---------	--	---

1 Introduction

This document is a practical user guide for code_saturne version 7.1. It is the result of the joint effort of all the members in the development team.

This document provides practical information for the usage of code_saturne. For more details about the algorithms and their numerical implementation, please refer to the reports [1], and [9], and to the theoretical documentation [10].

The latest updated version of this document is available on-line with the version of code_saturne and accessible through the command `code_saturne info --guide theory`.

This document presents some the necessary elements to run a calculation with code_saturne version 7.1. It then lists all the variables of the code which may be useful for more advanced users. The user subroutines of all the modules within the code are then documented. Eventually, for each keyword and user-modifiable parameter in the code, their definition, allowed values, default values and conditions for use are given. These keywords and parameters are grouped under headings based on their function. An alphabetical index is also given at the end of the document for easier reference.

In addition to the present user guide, a complete Doxygen documentation is available with code_saturne. It can provide information about the implementation such as details on variables used throughout the solver and the user subroutines. It also provides an easily explorable set of user subroutine examples and Fortran-C naming references for quantities linked to the mesh or the physical fields.

The user documentation is in the process of migration from this pdf documentation to the Doxygen documentation, so the user should first lok there. One can access the Doxygen main page through [this link](#) or from a terminal by typing the following command: `code_saturne info --guide theory`.

2 Basic modelling setup

2.1 Manage boundary conditions

The boundary conditions can be specified in the Graphical User Interface (GUI) under the heading “Boundary conditions” or in the user subroutine `cs_user_boundary_conditions` called every time step. With the GUI, each region and the type of boundary condition associated to it are defined in Figure 1. Then, the parameters of the boundary condition are specified in Figure 2. The colors of the boundary faces may be read directly from a “preprocessor.log” file created by the Preprocessor. This file can be generated directly by the interface under the heading “Definition of boundary regions → Add from Preprocessor log → import groups and references from Preprocessor log”, see Figure 1. `cs_user_boundary_conditions` is the second compulsory subroutine for every calculation launched without interface (except in the case of specific physics where the corresponding boundary condition user subroutine must be used).

When using the interface, only complex boundary conditions (input profiles, conditions varying in time, ...) need to be defined with `cs_user_boundary_conditions`. In the case of a calculation launched without the interface, all the boundary conditions must appear in `cs_user_boundary_conditions`.

`cs_user_boundary_conditions` is essentially constituted of loops on boundary face subsets. Several sequences of `call getfbr ('criterion', nlelt, lstelt)` (cf. §??) allow selecting the boundary faces with respect to their group(s), their color(s) or geometric criteria. If needed, geometric and physical variables are also available to the user. These allow him to select the boundary faces using other criteria.

For more details about the treatment of boundary conditions, the user may refer to the theoretical and computer documentation [10] of the subroutine `condli` (for wall conditions, see `clptur`) (to access this document on a workstation, use `code_saturne info --guide theory`).

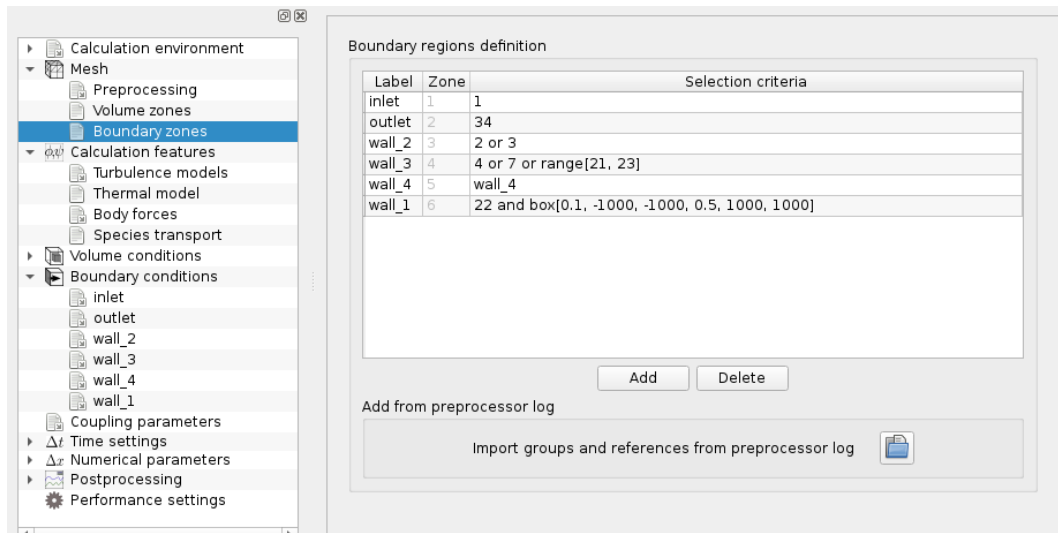

Figure 1: Definition of the boundary conditions

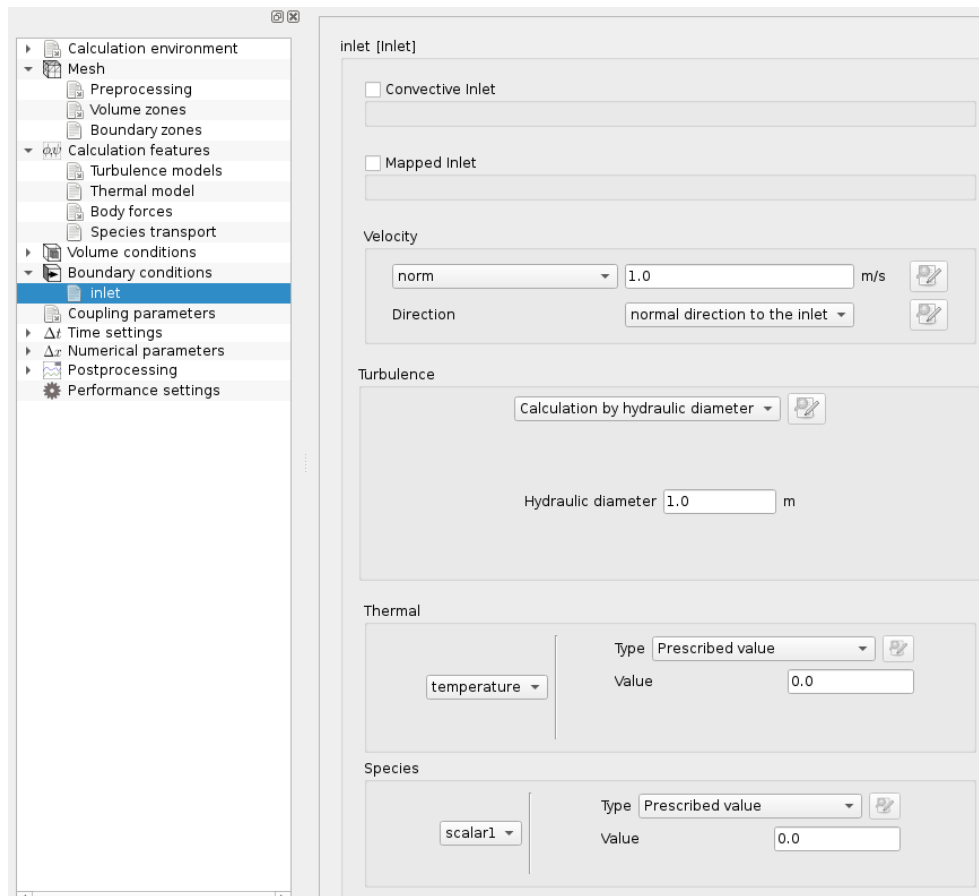

Figure 2: Parameters of the boundary conditions

From the user point of view, the boundary conditions are fully defined by three arrays¹: `itypfb(nfabor)`,

¹Except with Lagrangian boundary condition

`icodcl(nfabor,nvar)` and `rcodcl(nfabor,nvar,3)`.

- `itypfb(ifac)` defines the type of the face `ifac` (input, wall, ...).
- `icodcl(ifac,ivar)` defines the type of boundary condition for the variable `ivar` on the face `ifac` (Dirichlet, flux ...).
- `rcodcl(ifac,ivar,.)` gives the numerical values associated with the type of boundary condition (value of the Dirichlet condition, of the flux ...).

In the case of standard boundary conditions (see §2.1.1), it is sufficient to complete `itypfb(ifac)` and parts of the array `rcodcl`; the array `icodcl` and most of `rcodcl` are filled automatically. For non-standard boundary conditions (see §2.1.2), the arrays `icodcl` and `rcodcl` must be fully completed.

2.1.1 Coding of standard boundary conditions

The standard keywords used by the indicator `itypfb` are: `ientre`, `iparoi`, `iparug`, `isymet`, `isolib`, `ifrent`, `ifresf`, `i_convective_inlet` and `iindef`.

- If `itypfb=ientre`: inlet face.
 - Zero-flux condition for pressure and Dirichlet condition for all other variables. The value of the Dirichlet condition must be given in `rcodcl(ifac,ivar,1)` for every value of `ivar`, except for `ivar=ipr`. The other values of `rcodcl` and `icodcl` are filled automatically.
- If `itypfb=iparoi`: smooth solid wall face, impermeable and with friction.
 - the eventual sliding wall velocity of the face is found in `rcodcl(ifac,ivar,1)` (`ivar` being `iu`, `iv` or `iw`). The initial values of `rcodcl(ifac,ivar,1)` are zero for the three velocity components (and therefore are to be specified only if the velocity is not equal to zero).
WARNING: the wall sliding velocity must belong to the boundary face plane. For safety, the code only uses the projection of this velocity on the face. As a consequence, if the velocity specified by the user does not belong to the face plane, the wall sliding velocity really taken into account will be different.
 - For scalars, two kinds of boundary conditions can be defined:
 - ↪ Imposed value at the wall. The user must write

```
icodcl(ifac,ivar)=5
rcodcl(ifac,ivar,1)=imposed value
```
 - ↪ Imposed flux at the wall. The user must write

```
icodcl(ifac,ivar)=3
rcodcl(ifac,ivar,3)=imposed flux value (depending on the variable, the user
may refer to the case icodcl=3 of § 2.1.2 for the flux definition).
```
 - ↪ If the user does not fill these arrays, the default condition is zero flux.
- If `itypfb=iparug`: rough solid wall face, impermeable and with friction.
 - the eventual moving velocity of the wall tangent to the face is given by `rcodcl(ifac,ivar,1)` (`ivar` being `iu`, `iv` or `iw`). The initial value of `rcodcl(ifac,ivar,1)` is zero for the three velocity components (and therefore must be specified only in the case of the existence of a slipping velocity).
WARNING: the wall moving velocity must be in the boundary face plane. By security, the code uses only the projection of this velocity on the face. As a consequence, if the velocity specified by the user is not in the face plane, the wall moving velocity really taken into account will be different.

- The dynamic roughness must be specified in `rcodcl(ifac,iu,3)`. The values of `rcodcl(ifac,iv,3)` stores the thermal and scalar roughness. The values of `rcodcl(ifac,iw,3)` is not used.
- For scalars, two kinds of boundary conditions can be defined:
 - ↪ Imposed value at the wall. The user must write

```
icodcl(ifac,ivar)=6
rcodcl(ifac,ivar,1)=imposed value
```
 - ↪ Imposed flux at the wall. The user must write

```
icodcl(ifac,ivar)=3
rcodcl(ifac,ivar,3)= imposed flux value (definition of the flux condition according to the variable, the user can refer to the case icodcl=3 of the paragraph 2.1.2).
```
 - ↪ If the user does not complete these arrays, the default condition is zero flux.
- If `itypfb=isymet`: symmetry face (or wall without friction).
 - Nothing to be written in `icodcl` and `rcodcl`.
- If `itypfb=isolib`: free outlet face (or more precisely free inlet/outlet with forced pressure)
 - The pressure is always treated with a Dirichlet condition, calculated with the constraint $\frac{\partial}{\partial n} \left(\frac{\partial P}{\partial \tau} \right) = 0$. The pressure is set to P_0 at the first `isolib` face met. The pressure calibration is always done on a single face, even if there are several outlets.
 - If the mass flow is coming in, the velocity is set to zero and a Dirichlet condition for the scalars and the turbulent quantities is used (or zero-flux condition if no Dirichlet value has been specified).
 - If the mass flow is going out, zero-flux condition are set for the velocity, the scalars and the turbulent quantities.
 - Nothing is written in `icodcl` or `rcodcl` for the pressure or the velocity. An optional Dirichlet condition can be specified for the scalars and turbulent quantities.
- If `itypfb=ifrent`: free outlet, free inlet (based on Bernoulli relationship) face.
 - if outlet, the equivalent to standard outlet. In case of ingoing flux, the Benoulli relationship which links pressure and velocity is used (see the thory guide for more information). An additional head loss modelling what is going on outward of the domain can be added by the user.
- If `itypfb=ifresf`: free-surface boundary condition.
- If `itypfb=i_convective_inlet`: inlet with zero diffusive flux for all transported variables (species and velocity). This allows to exactly impose the ingoing flux.
- If `itypfb=iindef`: undefined type face (non-standard case).
 - Coding is done in a non-standard way by filling both arrays `rcodcl` and `icodcl` (see § 2.1.2).

NOTES

- Whatever is the value of the indicator `itypfb(ifac)`, if the array `icodcl(ifac,ivar)` is modified by the user (*i.e.* filled with a non-zero value), the code will not use the default conditions for the variable `ivar` at the face `ifac`. It will take into account only the values of `icodcl` and `rcodcl` provided by the user (these arrays must then be fully completed, like in the non-standard case). For instance, for a normal symmetry face where scalar 1 is associated with a Dirichlet condition equal to 23.8 (with an infinite exchange coefficient):

EDF R&D	code_saturne version 7.1 practical user's guide	code_saturne documentation Page 11/71
---------	--	---

```
itypfb(ifac)=isymet
icodcl(ifac,isca(1))=1
rcodcl(ifac,isca(1),1)=23.8
```

(`rcodcl(ifac,isca(1),2)=rinfin` is the default value, therefore it is not necessary to specify a value)
The boundary conditions for the other variables are automatically defined.

- The user can define new types of boundary faces. He only must choose a value N and to fully specify the boundary conditions (see §2.1.2). He must specify `itypfb(ifac)=N` where N range is 1 to `ntypmx` (maximum number of boundary face types), and of course different from the values `ientre`, `iparoi`, `iparug`, `isymet`, `isolib` and `iindef` (the values of these variables are given in the `paramx` module). This allows to easily isolate some boundary faces, in order for instance to calculate balances.

BOUNDARY CONDITION TYPES

The **gradient** boundary conditions in `code_saturne` boil down to determine a value for the current variable Y at the boundary faces f_b , that is to say Y_{f_b} , value expressed as a function of $Y_{I'}$, value of Y in I' , projection of the center of the adjacent cell on the straight line perpendicular to the boundary face and crossing its center:

$$Y_{f_b} = A_{f_b}^g + B_{f_b}^g Y_{I'}. \quad (1)$$

For a face `ifac`, the pair of coefficients $A_{f_b}^g$, $B_{f_b}^g$ is may be accessed using the `field_get_coefa_s` and `field_get_coefb_s` functions, replacing `s` with `v` for a vector.

The **flux** boundary conditions in `code_saturne` boil down to determine the value of the diffusive flux of the current variable Y at the boundary faces f_b , that is to say $D_{ib}(K_{f_b}, Y)$, value expressed as a function of $Y_{I'}$, value of Y in I' , projection of the center of the adjacent cell on the straight line perpendicular to the boundary face and crossing its center:

$$D_{ib}(K_{f_b}, Y) = A_{f_b}^f + B_{f_b}^f Y_{I'}. \quad (2)$$

For a face `ifac`, the pair of coefficients $A_{f_b}^f$, $B_{f_b}^f$ may be accessed using the `field_get_coefaf_s` and `field_get_coefbf_s` functions, replacing `s` with `v` for a vector.

The **divergence** boundary conditions in `code_saturne` boil down to determine a value for the current variable Y (mainly the Reynolds stress components, the divergence $\text{div}(\underline{R})$ used in the calculation of the momentum equation) at the boundary faces f_b , that is to say Y_{f_b} , value expressed as a function of $Y_{I'}$, value of Y in I' , projection of the center of the adjacent cell on the straight line perpendicular to the boundary face and crossing its center:

$$Y_{f_b} = A_{f_b}^d + B_{f_b}^d Y_{I'}. \quad (3)$$

For a face `ifac`, the pair of coefficients $A_{f_b}^d$, $B_{f_b}^d$ may be accessed using the `field_get_coefad_s` and `field_get_coefbd_s` functions, replacing `s` with `v` for a vector.

2.1.2 Coding of non-standard boundary conditions

If a face does not correspond to a standard type, the user must completely fill the arrays `itypfb`, `icodcl` and `rcodcl`. `itypfb(ifac)` is then equal to `iindef` or another value defined by the user (see note at the end of § 2.1.1). The arrays `icodcl` and `rcodcl` must be filled as follows:

- If `icodcl(ifac,ivar)=1`: Dirichlet condition at the face `ifac` for the variable `ivar`.
 - `rcodcl(ifac,ivar,1)` is the value of the variable `ivar` at the face `ifac`.
 - `rcodcl(ifac,ivar,2)` is the value of the exchange coefficient between the outside and the fluid for the variable `ivar`. An infinite value (`rcodcl(ifac,ivar,2)=rinfin`) indicates an ideal transfer between the outside and the fluid (default case).

EDF R&D	code_saturne version 7.1 practical user's guide	code_saturne documentation Page 12/71
---------	--	---

- `rcodcl(ifac,ivar,3)` is not used.
- `rcodcl(ifac,ivar,1)` has the units of the variable `ivar`, *i.e.*:
- ↪ m/s for the velocity
 - ↪ m^2/s^2 for the Reynolds stress
 - ↪ m^2/s^3 for the dissipation
 - ↪ Pa for the pressure
 - ↪ $^{\circ}C$ for the temperature
 - ↪ $J.kg^{-1}$ for the enthalpy
 - ↪ $^{\circ}C^2$ for temperature fluctuations
 - ↪ $J^2.kg^{-2}$ for enthalpy fluctuations
- `rcodcl(ifac,ivar,2)` has the following units (defined in such way that when multiplying the exchange coefficient by the variable, the given flux has the same units as the flux defined below when `icodcl=3`):
- ↪ $kg.m^{-2}.s^{-1}$ for the velocity
 - ↪ $kg.m^{-2}.s^{-1}$ for the Reynolds stress
 - ↪ $s.m^{-1}$ for the pressure
 - ↪ $W.m^{-2}.^{\circ}C^{-1}$ for the temperature
 - ↪ $kg.m^{-2}.s^{-1}$ for the enthalpy
- If `icodcl(ifac,ivar)=2`: radiative outlet at the face `ifac` for the variable `ivar`. It reads $\frac{\partial Y}{\partial t} + C \frac{\partial Y}{\partial n} = 0$, where C is a to be defined celerity of radiation.
 - `rcodcl(ifac,ivar,3)` is not used.
 - `rcodcl(ifac,ivar,1)` is the flux value of `ivar` at the cell center I' , projection of the center of the adjacent cell on the straight line perpendicular to the boundary face and crossing its center, at the previous time step. It corresponds to:
 - `rcodcl(ifac,ivar,2)` is CFL number based on the parameter C , the distance to the boundary $I'F$ and the time step: $CFL = \frac{Cdt}{I'F}$,
 - If `icodcl(ifac,ivar)=3`: flux condition at the face `ifac` for the variable `ivar`.
 - `rcodcl(ifac,ivar,1)` and `rcodcl(ifac,ivar,2)` are not used.
 - `rcodcl(ifac,ivar,3)` is the flux value of `ivar` at the wall. This flux is negative if it is a source for the fluid. It corresponds to:
 - ↪ $-(\lambda_T + C_p \frac{\mu_t}{\sigma_T}) \nabla T \cdot \underline{n}$ for a temperature (in W/m^2)
 - ↪ $-(\frac{\lambda_T}{C_p} + \frac{\mu_t}{\sigma_h}) \nabla h \cdot \underline{n}$ for an enthalpy (in W/m^2).
 - ↪ $-(\lambda_{\varphi} + \frac{\mu_t}{\sigma_{\varphi}}) \nabla \varphi \cdot \underline{n}$ in the case of another scalar φ (in $kg.m^{-2}.s^{-1}.[\varphi]$, where $[\varphi]$ are the units of φ).
 - ↪ $-\Delta t \nabla P \cdot \underline{n}$ for the pressure (in $kg.m^{-2}.s^{-1}$).
 - ↪ $-(\mu + \mu_t) \nabla U_i \cdot \underline{n}$ for a velocity component (in $kg.m^{-1}.s^{-2}$).
 - ↪ $-\mu \nabla R_{ij} \cdot \underline{n}$ for a R_{ij} tensor component (in W/m^2).
 - If `icodcl(ifac,ivar)=4`: symmetry condition, for the symmetry faces or wall faces without friction. This condition can only be used for velocity components ($\underline{U} \cdot \underline{n} = 0$) and the R_{ij} tensor components (for other variables, a zero-flux condition type is usually used).
 - If `icodcl(ifac,ivar)=5`: friction condition, for wall faces with friction. This condition can not be applied to the pressure.

↪ For the velocity and (if necessary) the turbulent variables, the values at the wall are calculated from theoretical profiles. In the case of a sliding wall, the three components of the sliding velocity are given by `(rcodcl(ifac,iu,1), rcodcl(ifac,iv,1), and rcodcl(ifac,iw,1))`.

WARNING: the wall sliding velocity must belong to the boundary face plane. For safety, the code uses only the projection of this velocity on the face. Therefore, if the velocity vector specified by the user does not belong to the face plane, the wall sliding velocity really taken into account will be different.

↪ For other scalars, the condition `icodcl=5` is similar to `icodcl=1`, but with a wall exchange coefficient calculated from a theoretical law. Therefore, the values of `rcodcl(ifac,ivar,1)` and `rcodcl(ifac,ivar,2)` must be specified: see [10].

- If `icodcl(ifac,ivar)=6`: friction condition, for the rough-wall faces with friction. This condition can not be used with the pressure.

↪ For the velocity and (if necessary) the turbulent variables, the values at the wall are calculated from theoretical profiles. In the case of a sliding wall, the three components of the sliding velocity are given by `(rcodcl(ifac,iu,1), rcodcl(ifac,iv,1), and rcodcl(ifac,iw,1))`.

WARNING: the wall sliding velocity must belong to the boundary face plane. For safety, the code uses only the projection of this velocity on the face. Therefore, if the velocity vector specified by the user does not belong to the face plane, the wall sliding velocity really taken into account will be different.

The dynamic roughness height is given by `rcodcl(ifac,iu,3)` only.

↪ For the other scalars, the condition `icodcl=6` is similar to `icodcl=1`, but with a wall exchange coefficient calculated from a theoretical law. The values of `rcodcl(ifac,ivar,1)` and `rcodcl(ifac,ivar,2)` must therefore be specified: see [10]. The thermal roughness height is then given by `rcodcl(ifac,ivar,3)`.

- If `icodcl(ifac,ivar)=9`: free outlet condition for the velocity. This condition is only applicable to velocity components.

If the mass flow at the face is negative, this condition is equivalent to a zero-flux condition.

If the mass flow at the face is positive, the velocity at the face is set to zero (but not the mass flow).

`rcodcl` is not used.

- If `icodcl(ifac,ivar)=14`: generalized symmetry boundary condition for vectors (Marangoni effect for the velocity for instance). This condition is only applicable to vectors and set a Dirichlet boundary condition on the normal component and a Neumann condition on the tangential components.

If the three components are `ivar1`, `ivar2`, `ivar3`, the required values are:

→ `rcodcl(ifac,ivar1,1)`: Dirichlet value in the *x* direction.

→ `rcodcl(ifac,ivar2,1)`: Dirichlet value in the *y* direction.

→ `rcodcl(ifac,ivar3,1)`: Dirichlet value in the *z* direction.

→ `rcodcl(ifac,ivar1,3)`: flux value for the *x* direction.

→ `rcodcl(ifac,ivar2,3)`: flux value for the *y* direction.

→ `rcodcl(ifac,ivar3,3)`: flux value for the *z* direction.

Therefore, the code automatically computes the boundary condition to impose to the normal and to the tangential components.

NOTE

- A standard `isolib` outlet face amounts to a Dirichlet condition (`icodcl=1`) for the pressure, a free

EDF R&D	code_saturne version 7.1 practical user's guide	code_saturne documentation Page 14/71
---------	--	---

outlet condition (`icodc1=9`) for the velocity and a Dirichlet condition (`icodc1=1`) if the user has specified a Dirichlet value or a zero-flux condition (`icodc1=3`) for the other variables.

2.1.3 Checking of the boundary conditions

The code checks the main compatibilities between the boundary conditions. In particular, the following rules must be respected:

- On each face, the boundary conditions of the three velocity components must belong to the same type. The same is true for the components of the R_{ij} tensor.
- If the boundary conditions for the velocity belong to the “sliding” type (`icodc1=4`), the conditions for R_{ij} must belong to the “symmetry” type (`icodc1=4`), and vice versa.
- If the boundary conditions for the velocity belong to the “friction” type (`icodc1=5` or `6`), the boundary conditions for the turbulent variables must belong to the “friction” type, too.
- If the boundary condition of a scalar belongs to the “friction” type, the boundary condition of the velocity must belong to the “friction” type, too.

In case of mistakes, if the post-processing output is activated (which is the default setting), a special error output, similar to the mesh format, is produced in order to help correcting boundary condition definitions.

2.1.4 Sorting of the boundary faces

In the code, it may be necessary to have access to all the boundary faces of a given type. To ease this kind of search, an array made of sorted faces is automatically filled (and updated at each time step): `itrifb(nfabor)`.

`ifac=itrifb(i)` is the number of the i^{th} face of type 1.

`ifac=itrifb(i+n)` is the number of the i^{th} face of type 2, if there are n faces of type 1.

... etc.

Two auxiliary arrays of size `ntypmx` are also defined.

`idebty(ityp)` is the index corresponding to the first face of type `ityp` in the array `itrifb`.

`ifinty(ityp)` is the index corresponding to the last face of type `ityp` in the array `itrifb`.

Therefore, a value `ifac0` found between `idebty(ityp)` and `ifinty(ityp)` is associated to each face `ifac` of type `ityp=itypfb(ifac)`, so that `ifac=itrifb(ifac0)`.

If there is no face of type `ityp`, the code set

`ifinty(ityp)=idebty(ityp)-1`,

which enables to bypass, for all the missing `ityp`, the loops such as

`do ii=idebty(ityp),ifinty(ityp)`.

The values of all these indicators are displayed at the beginning of the code execution log.

2.2 User source terms

Assume, for example, that the user source terms modify the equation of a variable φ in the following way:

$$\rho \frac{\partial \varphi}{\partial t} + \dots = \dots + S_{impl} \times \varphi + S_{expl}$$

The example is valid for a velocity component, for a turbulent variable (k , ε , R_{ij} , ω , φ or \bar{f}) and for a scalar (or for the average of the square of the fluctuations of a scalar), because the syntax of all the subroutines `ustsnv`, `cs_user_turbulence_source_terms` and `ustssc` in the `cs_user_source_terms` file is similar.

EDF R&D	code_saturne version 7.1 practical user's guide	code_saturne documentation Page 15/71
---------	--	---

In the finite volume formulation, the solved system is then modified as follows:

$$\left(\frac{\rho_i \Omega_i}{\Delta t_i} - \Omega_i S_{impl,i} \right) (\varphi_i^{(n+1)} - \varphi_i^{(n)}) + \dots = \dots + \Omega_i S_{impl,i} \varphi_i^{(n)} + \Omega_i S_{expl,i}$$

The user needs therefore to provide the following values:

$$\mathbf{crvimp}_i = \Omega_i S_{impl,i}$$

$$\mathbf{crvexp}_i = \Omega_i S_{expl,i}$$

In practice, it is essential for the term $\left(\frac{\rho_i \Omega_i}{\Delta t_i} - \Omega_i S_{impl,i} \right)$ to be positive. To ensure this property, the equation really taken into account by the code is the following:

$$\left(\frac{\rho_i \Omega_i}{\Delta t_i} - \text{Min}(\Omega_i S_{impl,i}; 0) \right) (\varphi_i^{(n+1)} - \varphi_i^{(n)}) + \dots = \dots + \Omega_i S_{impl,i} \varphi_i^{(n)} + \Omega_i S_{expl,i}$$

To make the “implication” effective, the source term decomposition between the implicit and explicit parts will be done by the user who must ensure that $\mathbf{crvimp}_i = \Omega_i S_{impl,i}$ is always negative (otherwise the solved equation remains right, but there will not be “implication”).

WARNING: When the second-order in time is used along with the extrapolation of the source terms², it is no longer possible to test the sign of $S_{impl,i}$, because of coherence reasons (for more details, the user may refer to the theoretical and computer documentation [10] of the subroutine `preduv`). The user must therefore make sure it is always positive (or take the risk to affect the calculation stability).

PARTICULAR CASE OF A LINEARISED SOURCE TERM

In some cases, the added source term is not linear, but the user may want to linearise it using a first-order Taylor development, in order to make it partially implicit.

Consider an equation of the type:

$$\rho \frac{\partial \varphi}{\partial t} = F(\varphi)$$

To make it implicit using the following method:

$$\begin{aligned} \frac{\rho_i \Omega_i}{\Delta t} (\varphi_i^{(n+1)} - \varphi_i^{(n)}) &= \Omega_i \left[F(\varphi_i^{(n)}) + (\varphi_i^{(n+1)} - \varphi_i^{(n)}) \frac{dF}{d\varphi}(\varphi_i^{(n)}) \right] \\ &= \Omega_i \frac{dF}{d\varphi}(\varphi_i^{(n)}) \times \varphi_i^{(n+1)} + \Omega_i \left[F(\varphi_i^{(n)}) - \frac{dF}{d\varphi}(\varphi_i^{(n)}) \times \varphi_i^{(n)} \right] \end{aligned}$$

The user must therefore specify:

$$\mathbf{crvimp}_i = \Omega_i \frac{dF}{d\varphi}(\varphi_i^{(n)})$$

$$\mathbf{crvexp}_i = \Omega_i \left[F(\varphi_i^{(n)}) - \frac{dF}{d\varphi}(\varphi_i^{(n)}) \times \varphi_i^{(n)} \right]$$

Example:

If the equation is $\rho \frac{\partial \varphi}{\partial t} = -K \varphi^2$, the user must set:

$$\mathbf{crvimp}_i = -2K \Omega_i \varphi_i^{(n)}$$

$$\mathbf{crvexp}_i = K \Omega_i [\varphi_i^{(n)}]^2$$

2.2.1 In Navier-Stokes

The source term in Navier-Stokes can be filled in thanks to the GUI or the `cs_user_source_terms` user file. Without the GUI, the subroutine `ustsnv` is used to add user source terms to the Navier-Stokes equations (at each time step).

²indicator `isno2t` for the velocity, `isto2t` for the turbulence and `isso2t` for the scalars

EDF R&D	code_saturne version 7.1 practical user's guide	code_saturne documentation Page 16/71
---------	--	---

`ustsnv` is called only once per time step; for each cell `iel`, the vector `crvexp(.,iel)` (explicit part) and the matrix `crvimp(.,.,iel)` (implicit part) must be filled in for the whole velocity vector.

2.2.2 For k and ε

Subroutine called every time step, for the $k - \varepsilon$ and the $v2f$ models.

The subroutine `cs_user_turbulence_source_terms` is used to add source terms to the transport equations related to the turbulent kinetics energy k and to the turbulent dissipation ε . This subroutine is called every time step (the treatment of the two variables k and ε is made simultaneously). The user is expected to provide the arrays `crkimp` and `crkexp` for k , and `creimp` and `creexp` for ε . These arrays are similar to the arrays `crvimp` and `crvexp` given for the velocity in the user subroutine `ustsnv`. The way of making implicit the resulting source terms is the same as the one presented in `ustsnv`. For φ and \bar{f} in the $v2f$ model, see `cs_user_turbulence_source_terms`, §2.2.4.

2.2.3 For R_{ij} and ε

Subroutine called every time step, for the $R_{ij} - \varepsilon$ models.

The subroutine `cs_user_turbulence_source_terms` is used to add source terms to the transport equations related to the Reynolds stress variables R_{ij} and to the turbulent dissipation ε . This subroutine is called 7 times every time step (once for each Reynolds stress component and once for the dissipation). The user must provide the arrays `crvimp` and `crvexp` for the field variable of index `f_id` (referring successively to `ir11`, `ir22`, `ir33`, `ir12`, `ir13`, `ir23` and `iep`). These arrays are similar to the arrays `crvimp` and `crvexp` given for the velocity in the user subroutine `ustsnv`. The method for impliciting the resulting source terms is the same as that presented in `ustsnv`.

2.2.4 For φ and \bar{f}

Subroutine called every time step, for the $v2f$ models.

The subroutine `cs_user_turbulence_source_terms` is used to add source terms to the transport equations related to the variables φ and \bar{f} of the $v2f$ φ -model. This subroutine is called twice every time step (once for φ and once for \bar{f}). The user is expected to provide the arrays `crvimp` and `crvexp` for `ivar` referring successively to `iphi` and `ifb`. Concerning φ , these arrays are similar to the arrays `crvimp` and `crvexp` given for the velocity in the user subroutine `ustsnv`. Concerning \bar{f} , the equation is slightly different:

$$L^2 \operatorname{div}(\nabla(\bar{f})) = \bar{f} + \dots + S_{impl} \times \bar{f} + S_{expl}$$

In the finite volume formulation, the solved system is written as:

$$\int_{\partial\Omega_i} \nabla(\bar{f})^{(n+1)} dS = \frac{1}{L_i^2} \left(\Omega_i \bar{f}_i^{(n+1)} + \dots + \Omega_i S_{impl,i} \bar{f}_i^{(n+1)} + \Omega_i S_{expl,i} \right)$$

The user must then specify:

$$\begin{aligned} \text{crvimp}_i &= \Omega_i S_{impl,i} \\ \text{crvexp}_i &= \Omega_i S_{expl,i} \end{aligned}$$

The way of making implicit the resulting source terms is the same as the one presented in `ustsnv`.

2.2.5 For k and ω

Subroutine called every time step, for the $k - \omega$ SST model.

The subroutine `cs_user_turbulence_source_terms` is used to add source terms to the transport equations related to the turbulent kinetics energy k and to the specific dissipation rate ω . This subroutine is called every time step (the treatment of the two variables k and ω is made simultaneously). The

user is expected to provide the arrays `crkimp` and `crkexp` for the variable k , and the arrays `crwimp` and `crwexp` for the variable ω . These arrays are similar to the arrays `crvimp` and `crvexp` given for the velocity in the user subroutine `ustsnv`. The way of making implicit the resulting source terms is the same as the one presented in `ustsnv`.

2.2.6 For $\tilde{\nu}_t$

Subroutine called every time step, or the Spalart-Allmaras model.

The subroutine `cs_user_turbulence_source_terms` is used to add source terms to the transport equations related to the turbulent viscosity ν_t for the Spalart-Allmaras model. This subroutine is called every time step. The user is expected to provide the arrays `crkimp` and `crkexp` for the variable $\tilde{\nu}_t$. These arrays are similar to the arrays `crvimp` and `crvexp` given for the velocity in the user subroutine `ustsnv`. The way of making implicit the resulting source terms is the same as the one presented in `ustsnv`.

2.2.7 For user scalars

Subroutine called every time step.

The source terms in the transport equations related to the user scalars (passive or not, average of the square of the fluctuations of a scalar, ...) can be filled in thanks to the GUI or the `cs_user_source_terms` user file. Without the GUI, the subroutine `ustssc` is used to add source terms to the transport equations related to the user scalars. In the same way as `ustsnv`, this subroutine is called every time step, once for each user scalar. The user must provide the arrays `crvimp` and `crvexp` related to each scalar. `cvimp` and `cvexp` must be set to 0 for the scalars on which it is not wished for the user source term to be applied (the arrays are initially set to 0 at each inlet in the subroutine).

3 Advanced modelling setup

3.1 Use of a specific physics

Specific physics such as dispersed phase, atmospheric flows, gas combustion, pulverised fuel combustion, electrical model and compressible model can be added by the user from the interface, or by using the subroutine `usppmo` of the `cs_user_parameters.f90` file (called only during the calculation initialisation). With the interface, when a specific physics is activated in Figure ??, additional items or headings may appear (see for instance Sections 3.6.4 and 3.2.0.1).

When the interface is not used, `usppmo` is one of the three subroutines which must be completed by the user in order to use a specific physics module (only heavy fuel combustion is not available with the GUI). At the moment, `code_saturne` allows to use two “pulverised coal” modules (with Lagrangian coupling or not) and one “pulverised heavy fuel” module, two “gas combustion” modules, two “electrical” modules, a “compressible” module, and an “atmospheric” module. To activate one of these modules, the user must complete one (and only one) of the indicators `ippmod(i.....)` in the subroutine `usppmo`. By default, all the indicators `ippmod(i.....)` are initialised at -1, which means that no specific physics is activated.

- Diffusion flame in the framework of “3 points” rapid complete chemistry: indicator `ippmod(icod3p)`
 - `ippmod(icod3p) = 0` adiabatic conditions
 - `ippmod(icod3p) = 1` permeatic conditions (enthalpy transport)
 - `ippmod(icod3p) = -1` module not activated
- Eddy Break Up pre-mixed flame: indicator `ippmod(icoebu)`

EDF R&D	code_saturne version 7.1 practical user's guide	code_saturne documentation Page 18/71
---------	--	---

- `ippmod(icoebu) = 0` adiabatic conditions at constant richness
- `ippmod(icoebu) = 1` permeatic conditions at constant richness
- `ippmod(icoebu) = 2` adiabatic conditions at variable richness
- `ippmod(icoebu) = 3` permeatic conditions at variable richness
- `ippmod(icoebu) = -1` module not activated
- Libby-Williams pre-mixed flame: indicator `ippmod(icolwc)`
 - `ippmod(icolwc)=0` two peak model with adiabatic conditions.
 - `ippmod(icolwc)=1` two peak model with permeatic conditions.
 - `ippmod(icolwc)=2` three peak model with adiabatic conditions.
 - `ippmod(icolwc)=3` three peak model with permeatic conditions.
 - `ippmod(icolwc)=4` four peak model with adiabatic conditions.
 - `ippmod(icolwc)=5` four peak model with permeatic conditions.
 - `ippmod(icolwc)=-1` module not activated.
- Multi-coals and multi-classes pulverised coal combustion: indicator `ippmod(iccoal)` The number of different coals must be less than or equal to `ncharm = 3`. The number of particle size classes `nclpch(icha)` for the coal `icha`, must be less than or equal to `ncpcmx = 10`.
 - `ippmod(iccoal) = 0` imbalance between the temperature of the continuous and the solid phases
 - `ippmod(iccoal) = 1` otherwise
 - `ippmod(iccoal) = -1` module not activated
- Multi-classes pulverised heavy fuel combustion: indicator `ippmod(icfuel)`
 - `ippmod(icfuel) = 0` module activated
 - `ippmod(icfuel) = -1` module not activated
- Lagrangian modelling of multi-coals and multi-classes pulverised coal combustion: indicator `ippmod(icpl3c)` The number of different coals must be less than or equal to `ncharm = 3`. The number of particle size classes `nclpch(icha)` for the coal `icha`, must be less than or equal to `ncpcmx = 10`.
 - `ippmod(icpl3c) = 1` coupling with the Lagrangian module, with transport of H_2
 - `ippmod(icpl3c) = -1` module not activated
- Electric arcs module (Joule effect and Laplace forces): indicator `ippmod(ielarc)`
 - `ippmod(ielarc) = 1` determination of the magnetic field by means of the Ampere's theorem (not available)
 - `ippmod(ielarc) = 2` determination of the magnetic field by means of the vector potential
 - `ippmod(ielarc) = -1` module not activated
- Joule effect module (Laplace forces not taken into account): indicator `ippmod(ieljou)`
 - `ippmod(ieljou) = 1` use of a real potential
 - `ippmod(ieljou) = 2` use of a complex potential
 - `ippmod(ieljou) = 3` use of real potential and specific boundary conditions for transformers.
 - `ippmod(ieljou) = 4` use of complex potential and specific boundary conditions for transformers.
 - `ippmod(ieljou) = -1` module not activated

EDF R&D	code_saturne version 7.1 practical user's guide	code_saturne documentation Page 19/71
---------	--	---

- Compressible module: indicator `ippmod(icompf)`
 - `ippmod(icompf) = 0` module activated
 - `ippmod(icompf) = -1` module not activated
- Atmospheric flow module: indicator `ippmod(iatmos)`
 - `ippmod(iatmos) = -1` module not activated
 - `ippmod(iatmos) = 0` standard modelling
 - `ippmod(iatmos) = 1` dry atmosphere
 - `ippmod(iatmos) = 2` humid atmosphere

WARNING: Only one specific physics module can be activated at the same time.

In the framework of the gas combustion modelling, the user may impose his own enthalpy-temperature tabulation (conversion law). He needs then to give the value zero to the indicator `indjon` (the default value being 1). For more details, the user may refer to the following note (thermochemical files).

NOTE: THE THERMO-CHEMICAL FILES

The user must not forget to place in the directory DATA the thermochemical file `dp_C3P`, `dp_C3PSJ` or `dp_ELE` (depending on the specific physics module he activated) Some example files are placed in the directory DATA/REFERENCE at the creation of the study case. Their content is described below.

- Example of file for the gas combustion:
 - if the enthalpy-temperature conversion data base JANAF is used: `dp_C3P` (see array 1).
 - if the user provides his own enthalpy-temperature tabulation (there must be three chemical species and only one reaction): `dp_C3PSJ` (see array 2). This file replaces `dp_C3P`.
- Example of file for the electric arcs: `dp_ELE` (see array 3).

Lines	Examples of values	Variables	Observations
1	5	ngaze	Number of current species
2	10	npo	Number of points for the enthalpy-temperature table
3	300.	tmin	Lower temperature limit for the table
4	3000.	tmax	Upper temperature limit for the tabulation
5			Empty line
6	CH4 O2 CO2 H2O N2	nomcoe(ngaze)	List of the current species
7	.35 .35 .35 .35 .35	kabse(ngaze)	Absorption coefficient of the current species
8	4	nato	Number of elemental species
9	.012 1 0 1 0 0	wmolat(nato),	Molar mass of the elemental species (first column)
10	.001 4 0 0 2 0	atgaze(ngaze,nato)	Composition of the current species as a function of the elemental species (ngaze following columns)
11	.016 0 2 2 1 0		
12	.014 0 0 0 0 2		
13	3	ngazg	Number of global species Here, ngazg = 3 (Fuel, Oxidiser and Products)
14	1. 0. 0. 0. 0.	compog(ngaze,ngazg)	Composition of the global species as a function of the current species of line 6 In the order: Fuel (line 15), Oxidiser (line 16) and Product (line 17)
15	0. 1. 0. 0. 3.76		
16	0. 0. 1. 2. 7.52		
17	1	nrgaz	Number of global reactions Here nrgaz = 1 (always equal to 1 in this version)
18	1 2 -1 -9.52 10.52	igfuel(nrgaz), igoxy(nrgaz), stoeg(ngazg,nrgaz)	Numbers of the global species concerned by the stoichiometric ratio (first 2 integers) Stoichiometry in global species reaction. Negative for the reactants (here "Fuel" and "Oxidiser") and positive for the products (here "Products")

Table 1: Example of file for the gas combustion when JANAF is used: **dp_C3P**

Lines	Examples of values	Variables	Observations
1	6	npo	Number of tabulation points
2	50. -0.32E+07 -0.22E+06 -0.13E+08	th(npo), ehgazg(1,npo), ehgazg(2,npo), ehgazg(3,npo)	Temperature(first column), mass enthalpies of fuel, oxidiser and products (columns 2,3 and 4) from line 2 to line npo +1
3	250. -0.68E+06 -0.44E+05 -0.13E+08		
4	450. 0.21E+07 0.14E+06 -0.13E+08		
5	650. 0.50E+07 0.33E+06 -0.12E+08		
6	850. 0.80E+07 0.54E+06 -0.12E+08		
7	1050. 0.11E+08 0.76E+06 -0.11E+08		
8	.00219 .1387 .159	wmolg(1), wmolg(2), wmolg(3)	Molar masses of fuel, oxidiser and products
9	.11111	fs(1)	Mixing rate at the stoichiometry (relating to Fuel and Oxidiser)
10	0.4 0.5 0.87	ckabsg(1), ckabsg(2), ckabsg(3)	Absorption coefficients of the fuel, oxidiser and products
11	1. 2.	xco2, xh2o	Molar coefficients of CO_2 and H_2O in the products (using Modak radiation)

Table 2: Example of file for the gas combustion when the user provides his own enthalpy-temperature table (there must be three species and only one reaction): **dp_C3PSJ** (this file replaces **dp_C3P**)

Lines	Examples of values	Variables	Observations
1	# Free format ASCII file ...		Free comment
2	# Comment lines ...		Free comment
3	# ...		Free comment
4	# Argon propoerties ...		Free comment
5	# ...		Free comment
6	# No of NGAZG and No ...		Free comment
7	# NGAZG NPO ...		Free comment
8	1 238	ngazg npo	Number of species Number of given temperature points for the tabulated physical properties (npo ≤ npot set in ppthch) So there will be ngazg blocks of npo lines each
9	# ...		Free comment
14	0	ixkabe	Radiation options for xkabe
15	# ...		Free comment
16	# Propreties ...		Free comment
17	# T H ...		Free comment
18	# Temperature Enthalpy ...		Free comment
19	# ...		Free comment
20	# K J/kg ...		Free comment
21	# ...		Free comment
22	300. 14000. ...	h roel cpel sigel visel xlabel xkabel	In line tabulation of the physical properties as a function of the temperature in Kelvin for each of the ngazg species Enthalpy in J/kg Density in kg/m3 Specific heat in J/(kg K) Electric conductivity in Ohm/m Dynamic viscosity in kg/(m s) Thermal conductivity in W/(m K) Absorption coefficient (radiation)

Table 3: Example of file for the electric arcs module: **dp_ELE**

3.2 Pulverised coal and gas combustion module (needs update)

3.2.0.1 Initialisation of the variables

For coal combustion, it is possible to initialise the specific variables in the Graphical User Interface (GUI) or in the subroutine `cs_user_initialization`. In the GUI, when a coal combustion physics is selected in the item “Calculation features” under the heading “Thermophysical models”, an additional item appears: “Pulverized coal combustion”. In this item the user can define coal types, their composition, the oxidant and reactions parameters, see Figure 3 to Figure 6.

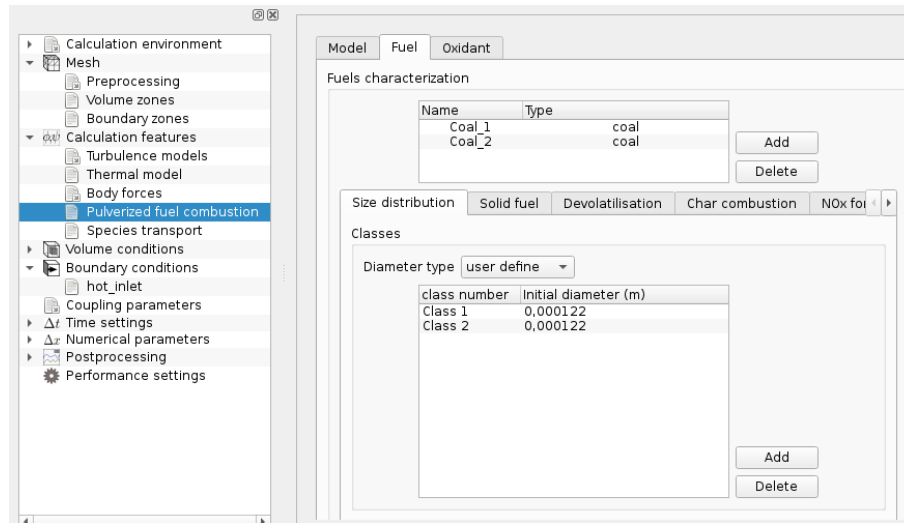

Figure 3: Thermophysical models - Pulverized coal combustion, coal classes

If the user deals with gas combustion or if he (or she) does not want to use the GUI for coal combustion, the subroutine `cs_user_initialization` must be used (only during the calculation initialisation). In this section, “specific physics” will refer to gas combustion or to pulverised coal combustion.

These subroutines allow the user to initialise some variables specific to the specific physics activated *via usppmo*. As usual, the user may have access to several geometric variables to discriminate between different initialisation zones if needed.

It should be recalled again that the user can access the array of values of the variables as described in the [the doxygen documentation dedicated to the fields management](#). In the following description, only variables indices `ivar` are given, but field indices can be retrieved easily by using `ivarfl(ivar)`.

WARNING: in the case of a specific physics modelling, all the variables will be initialised here, even the potential user scalars: `cs_user_initialization` is no longer used.

- in the case of the EBU pre-mixed flame module, the user can initialise in every cell `iel`: the mixing rate `isca(ifm)` in variable richness, the fresh gas mass fraction `isca(iyghm)` and the mixture enthalpy `isca(iscalt)` in permeatic conditions
- in the case of the rapid complete chemistry diffusion flame module, the user can initialise in every cell `iel`: the mixing rate `isca(ifm)`, its variance `isca(ifp2m)` and the mixture mass enthalpy `isca(iscalt)` in permeatic conditions
- in the case of the pulverised coal combustion module, the user can initialise in every cell `iel`:
 - the transport variables related to the solid phase
 - `isca(ixch(icla))` the reactive coal mass fraction related to the class `icla` (`icla` from 1 to `nclacp` which is the total number of classes, *i.e.* for all the coal type)

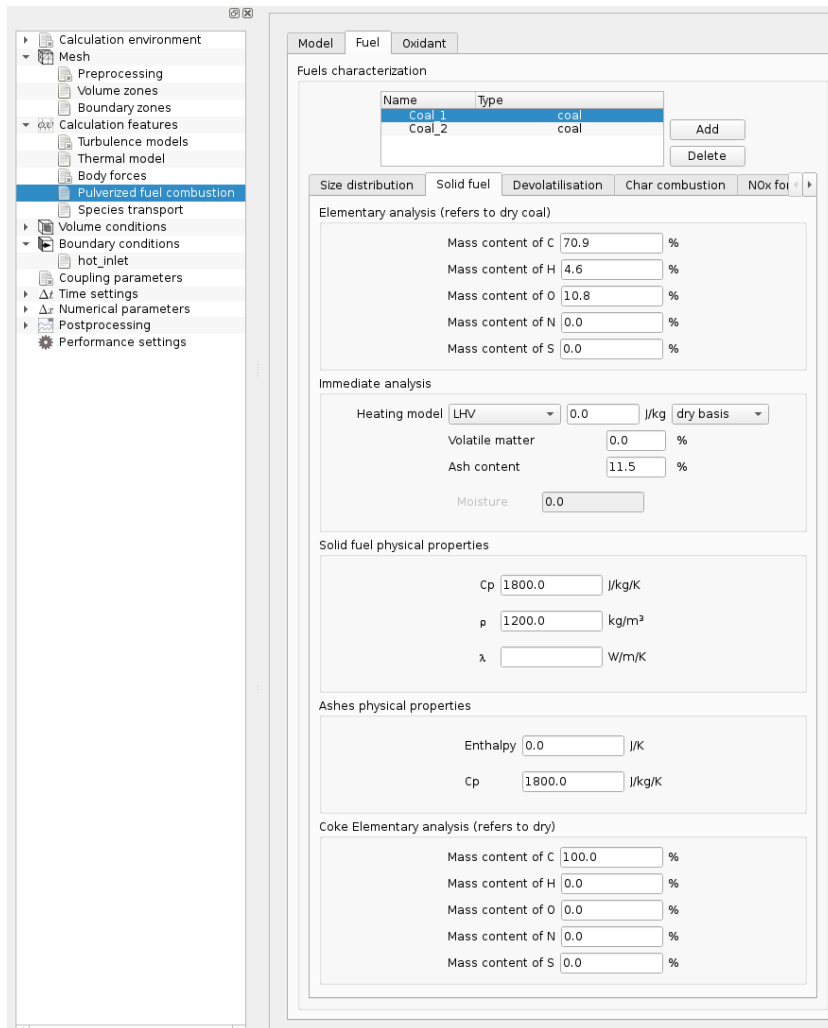

Figure 4: Pulverized coal combustion, coal composition

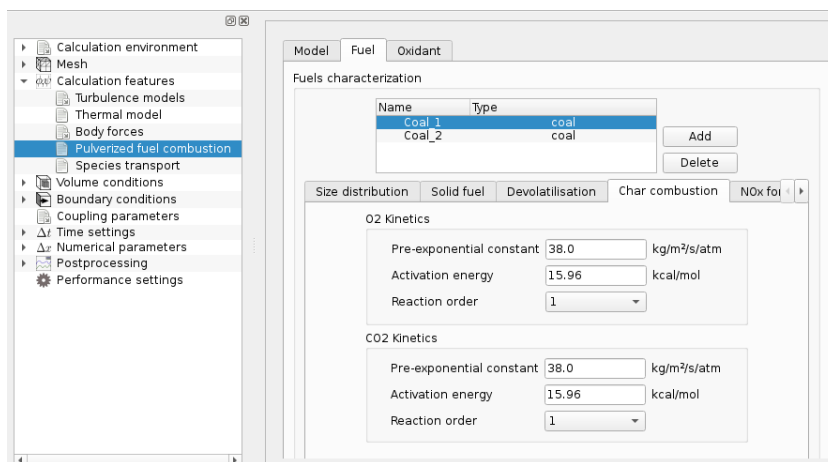

Figure 5: Pulverized coal combustion, reaction parameters

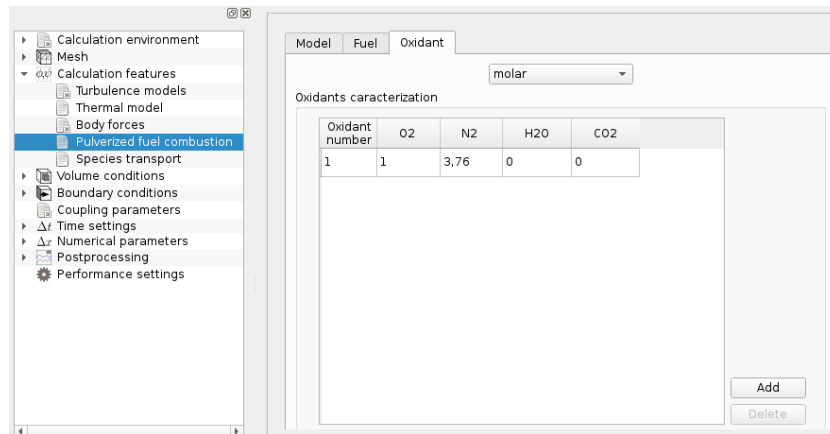

Figure 6: Pulverized coal combustion, oxydant

`isca(ixck(icla))` the coke mass fraction related to the class `icla`

`isca(inp(icla))` the number of particles related to class `icla` per kg of air-coal mixture

`isca(ih2(icla))` the mass enthalpy related to the class `icla` in permeatic conditions

→ `isca(iscalt)` the mixture enthalpy

→ the transport variables related to the gas phase

`isca(if1m(icha))` the mean value of the tracer 1 representing the light volatile matters released by the coal `icha`

`isca(if2m(icha))` the mean value of the tracer 2 representing the heavy volatile matters released by the coal `icha`

`isca(if3m)` the mean value of the tracer 3 representing the carbon released as CO during coke burnout

`isca(if4p2m)` the variance associated with the tracer 4 representing the air (the mean value of this tracer is not transported, it can be deduced directly from the three others)

`isca(ifp3m)` the variance associated with the tracer 3

3.2.1 Boundary conditions

In this section, “specific physics” refers to gas combustion or to pulverised coal combustion.

For coal combustion, it is possible to manage the boundary conditions in the Graphical User Interface (GUI). When the coal combustion physics is selected in the heading “Thermophysical models”, specific boundary conditions are activated for inlets, see Figure 7. The user fills for each type of coal previously defined (see § 3.2.0.1) the initial temperature and initial composition of the inlet flow, as well as the mass flow rate.

For gas combustion or if the GUI is not used for coal combustion, the use of `cs_user_boundary_conditions` (called at every time step) is as mandatory as `cs_user_parameters.f90` and `usppmo` to run a calculation involving specific physics. The way of using them is the same as using in the framework of standard calculations, that is, run several loops on the boundary faces lists (cf. §??) marked out by their colors, groups, or geometrical criterion, where the type of face, the type of boundary condition for each variable and eventually the value of each variable are defined.

WARNING: In the case of a specific physics modelling, all the boundary conditions for every variable must be defined here, even for the eventual user scalars: `cs_user_boundary_conditions` is not used at all.

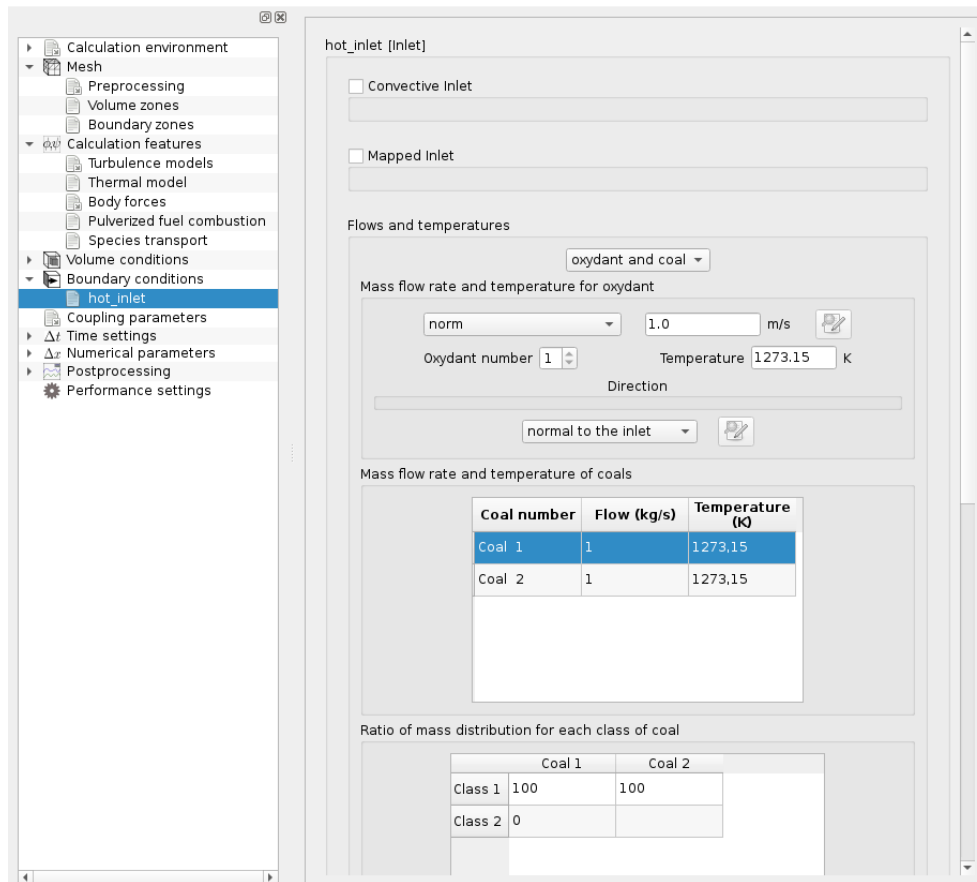

Figure 7: Boundary conditions for the combustion of coal

In the case of a specific physics modelling, a zone number $izone$ ³ (for instance the color `icoul`) is associated with every boundary face, in order to gather together all the boundary faces of the same type. In comparison to `cs_user_boundary_conditions`, the main change from the user point of view concerns the faces whose boundary conditions belong to the type `itypfb=ientre`:

- for the EBU pre-mixed flame module:
 - the user can choose between the “burned gas inlet” type (marked out by the burned gas indicator `ientgb(izone)=1`) and the “fresh gas inlet” type (marked out by the fresh gas indicator `ientgf(izone)=1`)
 - for each inlet type (fresh or burned gas), a mass flow or a velocity must be imposed:
 - to impose the mass flow,
 - the user gives to the indicator `iqimp(izone)` the value 1,
 - the mass flow value is set in `qimp(izone)` (positive value, in $kg\ s^{-1}$)
 - finally he imposes the velocity vector direction by giving the components of a direction vector in `rcodcl(ifac,iu)`, `rcodcl(ifac,iv)` and `rcodcl(ifac,iw)`

WARNING:

- the variable `qimp(izone)` refers to the mass flow across the whole zone `izone` and not across a boundary face (specifically for the axi-symmetric calculations, the inlet surface of the mesh must be broken up)

³`izone` must be less than the maximum number of boundary zone allowable by the code, `nozppm`. This is fixed at 2000 in `pppvar`; not to be modified

- the variable $q_{imp}(izone)$ deals with the inflow across the area $izoz$ and only across this zone; it is recommended to pay attention to the boundary conditions.
- the velocity direction vector is neither necessarily normed, nor necessarily incoming.
- to impose a velocity, the user must give to the indicator $iq_{imp}(izone)$ the value 0 and set the three velocity components (in $m.s^{-1}$) in $rcodcl(ifac,iu)$, $rcodcl(ifac,iv)$ and $rcodcl(ifac,iw)$

→ finally he specifies for each gas inlet type the mixing rate $f_{ment}(izone)$ and the temperature $t_{kent}(izone)$ in Kelvin

- for the “3 points” diffusion flame module:

→ the user can choose between the “oxidiser inlet” type marked out by $ientox(izone)=1$ and the “fuel inlet” type marked out by $ientfu(izone)=1$

→ concerning the input mass flow or the input velocity, the method is the same as for the EBU pre-mixed flame module

→ finally, the user sets the temperatures t_{inoxy} for each oxidiser inlet and t_{infue} , for each fuel inlet

Note: In the standard version, only the cases with only one oxidising inlet type and one fuel inlet type can be treated. In particular, there must be only one input temperature for the oxidiser (t_{inoxy}) and one input temperature for the fuel (t_{infuel}).

- for the pulverised coal module:

→ the inlet faces can belong to the “primary air and pulverised coal inlet” type, marked out by $ientcp(izone)=1$, or to the “secondary or tertiary air inlet” type, marked out by $ientat(izone)=1$

→ in a way which is similar to the process described in the framework of the EBU module, the user chooses for every inlet face to impose the mass flow or not ($iq_{imp}(izone)=1$ or 0). If the mass flow is imposed, the user must set the air mass flow value $q_{impat}(izone)$, its direction in $rcodcl(ifac,iu)$, $rcodcl(ifac,iv)$ and $rcodcl(ifac,iw)$ and if

→ incoming air temperature $t_{impat}(izone)$ in Kelvin. If the velocity is imposed, he must set $rcodcl(ifac,iu)$, $rcodcl(ifac,iv)$ and $rcodcl(ifac,iw)$.

→ if the inlet belongs to the “primary air and pluverised coal” type ($ientcp(izone) = 1$) the user must also define for each coal type $icha$: the mass flow $q_{impcp}(izone,icha)$, the granulometric distribution $distch(izone,icha,iclacp)$ related to each class $iclacp$, and the injection temperature $t_{impcp}(izone,icha)$

3.2.2 Initialisation of the options of the variables

In the case of coal combustion, time averages, chronological records and logss follow-ups can be set in the Graphical User Interface (GUI) or in the subroutines `cs_user_combustion`. In the GUI, under the heading “Calculation control”, additional variables appear in the list in the items “Time averages” and “Profiles”, as well as in the item Volume solution control”, see Figure 8 and Figure 9.

In this section, “specific physics” refers to gas combustion or pulverised coal combustion.

For gas combustion or if the GUI is not used for coal combustion, the 3 subroutines `cs_user_combustion` can be used to complete `cs_user_parameters.f90` for the considered specific physics. These subroutines are called at the calculation start. They allow to:

- activate, for the variables which are specific to the activated specific physics module, chronological records at the probes defined in `cs_user_parameters.f90`.

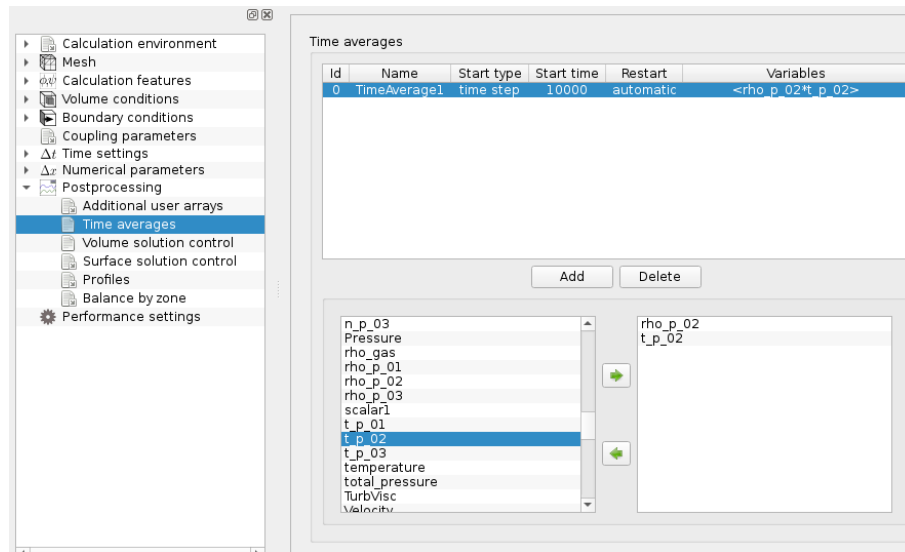

Figure 8: Calculation control - Time averages

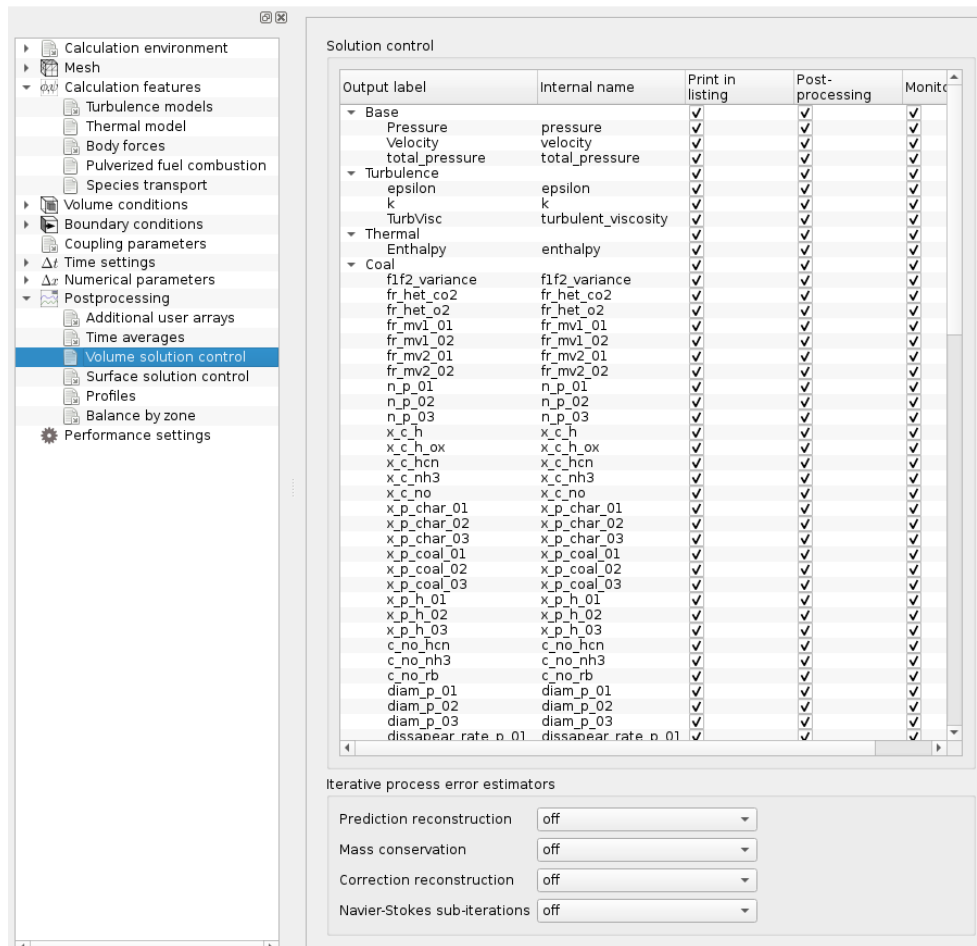

Figure 9: Calculation control - Volume solution control

EDF R&D	code_saturne version 7.1 practical user's guide	code_saturne documentation Page 28/71
---------	--	---

Concerning the main variables (velocity, pressure, etc ...) the user must still complete `cs_user_parameters.f90` if he wants to get chronological records, printings in the log or chronological outputs. The variables which can be activated by the user for each specific physics are listed below. The solved variables (of variable indices `ivar`) and the properties of indices `iprop` (defined at the cell `iel` by `cpro_prop(iel)` which is obtained by calling `field_get_val_s(iprop, cpro_prop)`) are listed below:

→ EBU pre-mixed flame modelling:

- Solved variables
 - `ivar = isca(iyghm)` fresh gas mass fraction
 - `ivar = isca(ifm)` mixing rate
 - `ivar = isca(ihm)` enthalpy, if transported
- Properties `cpro_prop(iel)`
 - `iprop = itemp` temperature
 - `iprop = iym(1)` fuel mass fraction
 - `iprop = iym(2)` oxidiser mass fraction
 - `iprop = iym(3)` product mass fraction
 - `iprop = ickabs` absorption coefficient, when the radiation modelling is activated
 - `iprop = it3m` and `it4m` " T^3 " and " T^4 " terms, when the radiation modelling is activated

→ rapid complete chemistry diffusion flame modelling:

everything is identical to the "EBU" case, except the fresh gas mass fraction which is replaced by the variance of the mixing rate `ivar=isca(ifp2m)`

→ pulverised coal modelling with 3 combustibles:

variables shared by the two phases:

- Solved variables
 - `ivar = isca(ihm)`: gas-coal mixture enthalpy
 - `ivar = isca(immel)`: molar mass of the gas mixture

variables specific to the dispersed phase:

- Solved variables
 - `ivar = isca(ixck(icla))`: coke mass fraction related to the class `icla`
 - `ivar = isca(ixch(icla))`: reactive coal mass fraction related to the class `icla`
 - `ivar = isca(inp(icla))`: number of particles of the class `icla` per kg of air-coal mixture
 - `ivar = isca(ih2(icla))`: mass enthalpy of the coal of class `icla`, if we are in permeatic conditions
- Properties `cpro_prop(iel)`
 - `iprop = immel`: molar mass of the gas mixture
 - `iprop = itemp2(icla)`: temperature of the particles of the class `icla`
 - `iprop = irom2(icla)`: density of the particles of the class `icla`
 - `iprop = idiam2(icla)`: diameter of the particles of the class `icla`
 - `iprop = igmdch(icla)`: disappearance rate of the reactive coal of the class `icla`
 - `iprop = igmdv1(icla)`: mass transfer caused by the release of light volatiles from the class `icla`
 - `iprop = igmdv2(icla)`: mass transfer caused by the release of heavy volatiles from the class `icla`
 - `iprop = igmhet(icla)`: coke disappearance rate during the coke burnout of the class `icla`
 - `iprop = ix2(icla)`: solid mass fraction of the class `icla`

EDF R&D	code_saturne version 7.1 practical user's guide	code_saturne documentation Page 29/71
---------	--	---

variables specific to the continuous phase:

- Solved variables
 - `ivar = isca(if1m(icha))`: mean value of the tracer 1 representing the light volatiles released by the coal `icha`
 - `ivar = isca(if2m(icha))`: mean value of the tracer 2 representing the heavy volatiles released by the coal `icha`
 - `ivar = isca(if3m)`: mean value of the tracer 3 representing the carbon released as CO during coke burnout
 - `ivar = isca(if4pm)`: variance of the tracer 4 representing the air
 - `ivar = isca(if3p2m)`: variance of the tracer 3
- Properties `cpro_prop(iel)`
 - `iprop = itemp`: temperature of the gas mixture
 - `iprop = iym1(1)`: mass fraction of CH_{X1m} (light volatiles) in the gas mixture
 - `iprop = iym1(2)`: mass fraction of CH_{X2m} (heavy volatiles) in the gas mixture
 - `iprop = iym1(3)`: mass fraction of CO in the gas mixture
 - `iprop = iym1(4)`: mass fraction of O_2 in the gas mixture
 - `iprop = iym1(5)`: mass fraction of CO_2 in the gas mixture
 - `iprop = iym1(6)`: mass fraction of H_2O in the gas mixture
 - `iprop = iym1(7)`: mass fraction of N_2 in the gas mixture
- set the relaxation coefficient of the density `srrom`, with $\rho^{n+1} = srrom * \rho^n + (1 - srrom)\rho^{n+1}$ (the default value is `srrom = 0.8`. At the beginning of a calculation, a sub-relaxation of 0.95 may reduce the numerical “shocks”).
- set the dynamic viscosity `dift10`. By default `dift10 = 4.25 kgm-1s-1` (the dynamic diffusivity being the ratio between the thermal conductivity λ and the mixture specific heat C_p in the equation of enthalpy).
- set the value of the constant `cebu` of the Eddy Break Up model (only in `cs_user_combustion`. By default `cebu=2.5`)

3.3 Heavy fuel oil combustion module

3.3.1 Initialisation of transported variables

To initialise or modify (in case of a continuation) values of transported variables and of the time step, the standard subroutine `cs_user_initialization` is used.

Physical properties are stored using the `cs_field` API (cell center). For instance, to obtain `rom(iel)`, the mean density (in $kg.m^{-3}$), one must declare a `ncelet` array `cpro_rom` and then call `call field_get_val_s(icrom, cpro_rom)`.

Physical properties (`rom`, `viscl`, `cp`, ...) are computed in `ppphyv` and are not to be modified here.

The `cs_user_initialization-fuel.f90` example illustrates how the user may initialise quantities related to gaseous species and droplets compositions in addition to the chosen turbulent model.

3.3.2 Boundary conditions

Boundary conditions are defined as usual on a per-face basis in `cs_user_boundary_conditions`. They may be assigned in two ways:

- for “standard” boundary conditions (inlet, free outlet, wall, symmetry): a code is defined in the array `itypfb` (of dimensions equal to the number of boundary faces). This code will then be used by a non-user subroutine to assign the conditions.

. for “non-standard” conditions: see details given in `cs_user_boundary_conditions-fuel.f90` example.

3.4 Radiative thermal transfers in semi-transparent gray media

3.4.1 Initialisation of the radiation main parameters

The main radiation parameters can be initialise in the Graphical User Interface (GUI) or in the user subroutine `cs_user_radiative_transfer_param`. In the GUI, under the heading “Thermophysical models”, when one of the two thermal radiative transfers models is selected, see Figure ??, additional items appear. The user is asked to choose the number of directions for angular discretisation, to define the absorption coefficient and select if the radiative calculation are restarted or not, see Figure 10 and Figure 12. When “Advanced options” is selected for both models Figure 11 or Figure 13 appear, the user must fill the resolution frequency and verbosity levels. In addition, the activation of the radiative transfer leads to the creation of an item “Surface solution control” under the heading “Calculation control”, see Figure 14, where radiative transfer variables can be selected to appear in the output log.

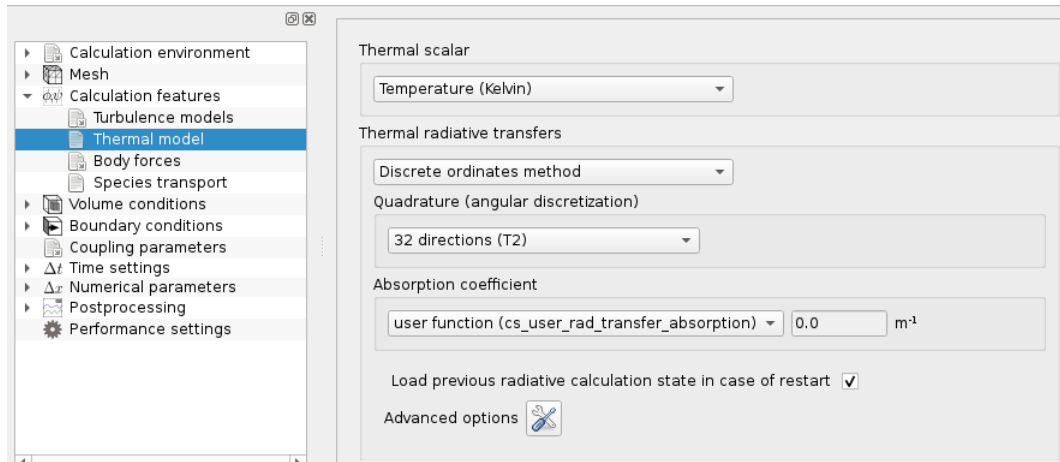

Figure 10: Radiative transfers - parameters of the DO method

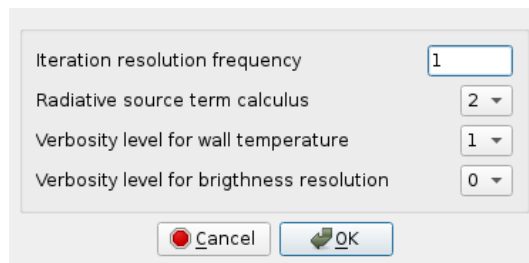

Figure 11: Radiative transfers - advanced parameters of the DO method

If the GUI is not used, `cs_user_radiative_transfer_param` is one of the two subroutine which must be completed by the user for all calculations including radiative thermal transfers. It is called only during the calculation initialisation. It is composed of three headings. The first one is dedicated to the activation of the radiation module, only in the case of classic physics.

WARNING: when a calculation is ran using a specific physics module, this first heading must not be completed. The radiation module is then activated or not, according to the parameter file related to the considered specific physics.

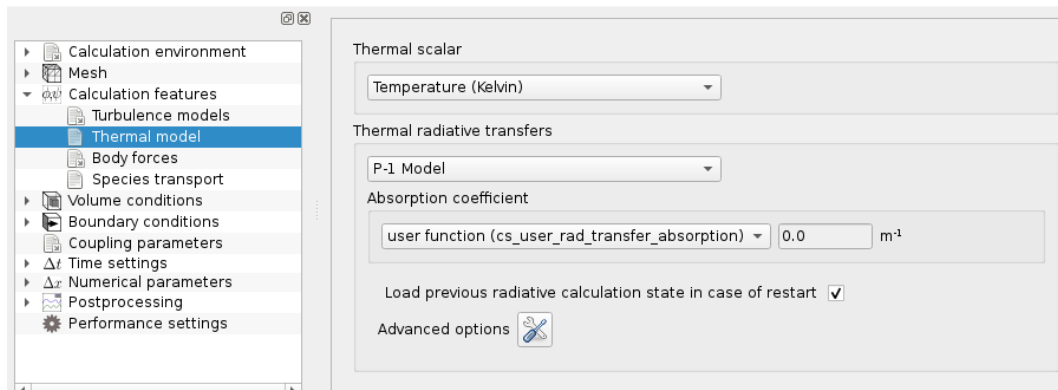

Figure 12: Radiative transfers - parameters of the P-1 model

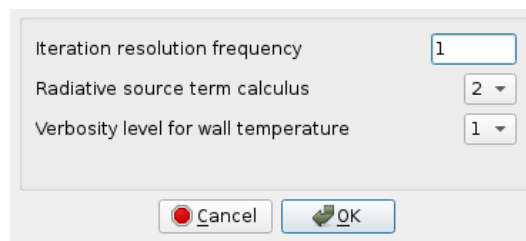

Figure 13: Radiative transfers - advanced parameters of the P-1 model

In the second heading the basic parameters of the radiation module are indicated.

Finally, the third heading deals with the selection of the post-processing graphic outputs. The variables to treat are splitted into two categories: the volumetric variables and those related to the boundary faces.

For more details about the different parameters, the user may refer to the keyword list (§ 4).

3.4.2 Radiative transfers boundary conditions

These informations can be filled by the user through the Graphical User Interface (GUI) or by using the subroutine `cs_user_radiative_transfer_bcs.c` (called every time step). If the interface is used, when one of the “Radiative transfers” options is selected in Figure ??, it activates specific boundary conditions each time a “Wall” is defined, see Figure 15. The user can then choose between 3 cases. The parameters the user must specify are displayed for one of them in Figure 16.

When the GUI is not used, `cs_user_radiative_transfer_bcs.c` is needed for every calculation which includes radiative thermal transfers. It is used to give all the necessary parameters concerning, in the one case, the wall temperature calculation, and in the other, the coupling between the thermal scalar (temperature or enthalpy), and the radiation module at the calculation domain boundaries. It must be noted that the boundary conditions concerning the thermal scalar which may have been defined in the GUI or in subroutine `cs_user_boundary_conditions` will be modified by the radiation module according to the data given in `cs_user_radiative_transfer_bcs` (cf. §??).

A boundary condition type stored in the array `isothp` is associated with each boundary face. There are five different types:

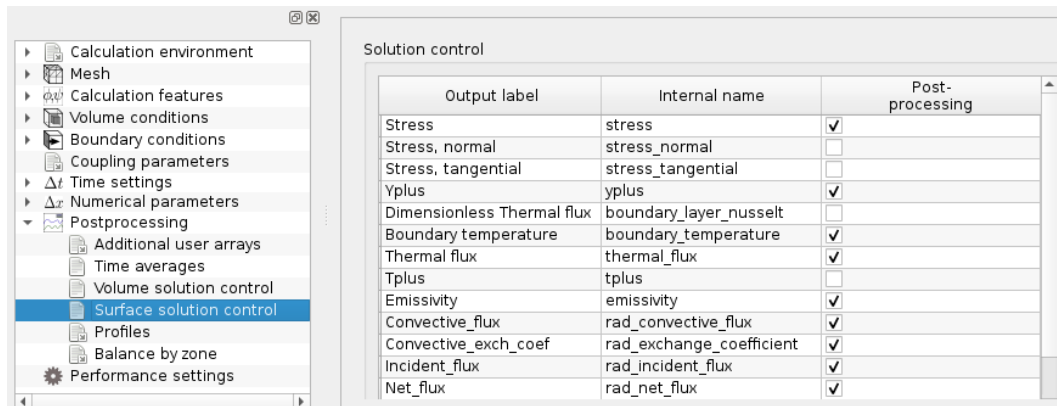

Figure 14: Calculation control - Radiative transfers post-processing output

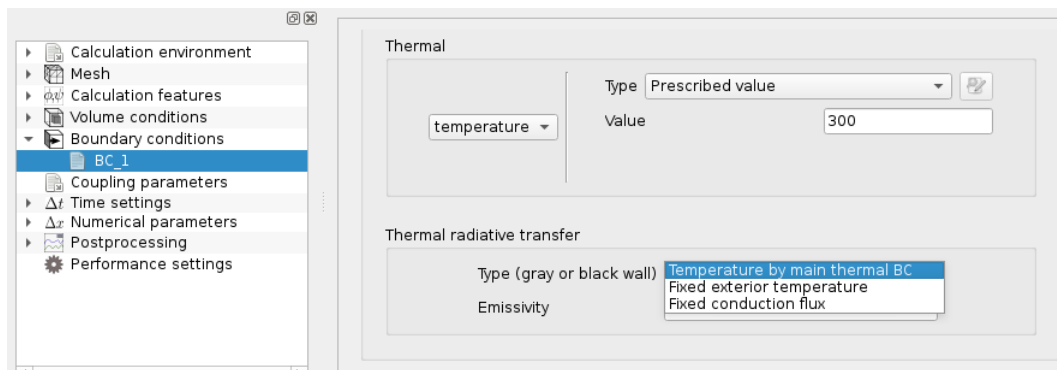

Figure 15: Boundary conditions - choice of wall thermal radiative transfers

- **CS_BOUNDARY_RAD_WALL_GREY**: grey of black wall, with temperature defined by main (fluid) boundary conditions,
- **CS_BOUNDARY_RAD_WALL_GREY_EXTERIOR.T**: grey or black wall, calculation of the temperature by means of a flux balance with an exterior temperature,
- **CS_BOUNDARY_RAD_WALL_REFL_EXTERIOR.T**: for a reflecting wall face, calculation of the temperature by means of a flux balance. This is equivalent to using **CS_BOUNDARY_RAD_WALL_GRAY_EXTERIOR** with zero emissivity.
- **CS_BOUNDARY_RAD_WALL_GRAY_COND_FLUX**: grey or black wall face to which a conduction flux is imposed,
- **CS_BOUNDARY_RAD_WALL_REFL_COND_FLUX**: reflecting wall face to which a conduction flux is imposed, which is equivalent to impose this flux directly to the fluid.
- **ifinfe**: for an open boundary (inlet or outlet) or symmetry face, simulate an infinite extrusion by applying a Neumann condition to the radiation equations,

Depending on the selected boundary condition type at every wall face, the code needs to be given some additional information:

- **CS_BOUNDARY_RAD_WALL_GRAY**: the array **eps** must be completed with the emissivity value (positive).

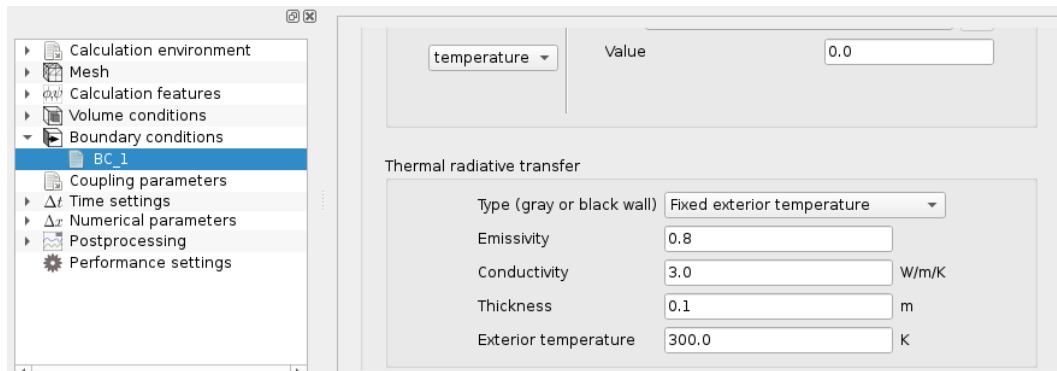

Figure 16: Boundary conditions - example of wall thermal radiative transfer

- `CS_BOUNDARY_RAD_WALL_GREY_EXTERIOR.T`: wall emissivity (strictly positive, in `epsp`), thickness (in `epap`), thermal conductivity (in `xlamp`) and external temperature (in `textp`) in order to calculate a conduction flux across the wall.
- `CS_BOUNDARY_RAD_WALL_REFL_EXTERIOR.T`: wall thickness (in `epap`) and thermal conductivity (in `xlamp`) and an external temperature (in `textp`). This is equivalent to using `CS_BOUNDARY_RAD_WALL_GREY_EXTERIOR.T` with a wall emissivity of 0, and an exchange coefficient-type boundary condition, where the exchange coefficient is equal to `xlamp / textp`.
- `CS_BOUNDARY_RAD_WALL_GRAY_COND_FLUX`: wall emissivity (in `epsp`) and conduction flux (in W/m^2 whatever the thermal scalar, enthalpy or temperature) in the array `rcodc1`. The value of `rcodc1` is positive when the conduction flux is directed from the inside of the fluid domain to the outside (for instance, when the fluid heats the walls). If the conduction flux is null, the wall is adiabatic.
- `CS_BOUNDARY_RAD_WALL_REFL_COND_FLUX`: must be given: the conduction flux (in W/m^2 whatever the thermal scalar) in the array `rcodc1`. The value of `rcodc1` is positive when the conduction flux is directed from the inside of the fluid domain to the outside (for instance, when the fluid heats the walls). If the conduction flux is null, the wall is adiabatic. The flux received by `rcodc1` is directly imposed as boundary condition for the fluid.

3.4.3 Absorption coefficient of the medium, boundary conditions for the luminance and calculation of the net radiative flux

When the absorption coefficient is not constant, the subroutine `cs_user_rad_transfer_absorption` is called instead at each time step. It is composed of three parts. In the first one, the user must provide the absorption coefficient of the medium in the array `CK`, for each cell of the fluid mesh. By default, the absorption coefficient of the medium is 0, which corresponds to a transparent medium.

WARNING: when a specific physics is activated, it is forbidden to give a value to the absorption coefficient in this subroutine. In this case, the coefficient is either calculated automatically, or provided by the user via a thermo-chemical parameter file (`dp_C3P` or `dp_C3PSJ` for gas combustion, and `dp_FCP` for pulverised coal combustion).

The two following parts of this subroutine concern a more advanced use of the radiation module. It is about imposing boundary conditions to the equation of radiative transfer and net radiative flux calculation, in coherence with the luminance at the boundary faces, when the user wants to give it a particular value. In most cases, the given examples do not need to be modified.

3.5 Conjugate heat transfer

3.5.1 Thermal module in a 1D wall

subroutine called at every time step

This subroutine takes into account the wall-affected thermal inertia. Some boundary faces are treated as a solid wall with a given thickness, on which the code resolves a one-dimensional equation for the heat conduction. The coupling between the 1D module and the fluid works in a similar way to the coupling with the SYRTHES. By construction, the user is not able to account for the heat transfer between different parts of the wall. A physical analysis of each problem, case by case is required in order to evaluate the relevance of its usage by way of a report of the simple conditions (temperature, zero-flux) or a coupling with SYRTHES.

The use of this code requires that the thermal scalar is defined as (`iscalt > 0`).

WARNING: The 1D thermal module is developed assuming the thermal scalar as a temperature. If the thermal scalar is an enthalpy, the code calls the enthalpy to temperature conversion as defined by the model defaults, or by the user in `cs_user_physical_properties` for each transfer of data between the fluid and the wall in order to convert the enthalpy to temperature and vice-versa. If the thermal variable is the total (compressible) energy, the thermal module will not work.

3.5.2 Internal Fluid-Thermal coupling

When at least one volume zone is defined as being solid (see Figure 17), scalar variables (especially thermal scalar variables) may be solved in a fully coupled manner across the fluid and solid domains.

For this purpose, the “Internal coupling” should be activated for the desired variables in the matching tab of the “Coupling parameters” page, as shown in figure Figure 18). This section should appear when at least one volume zone is defined as solid.

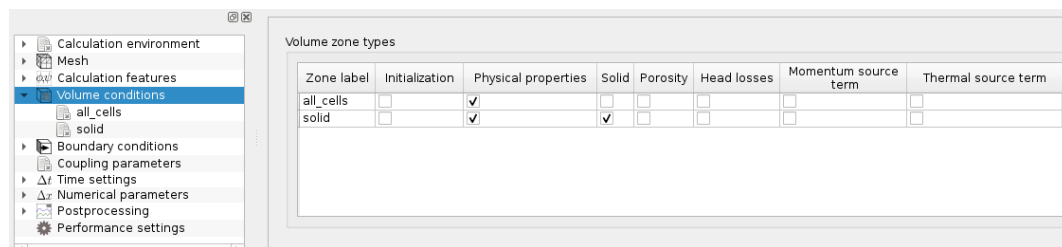

Figure 17: Solid volume zone definition

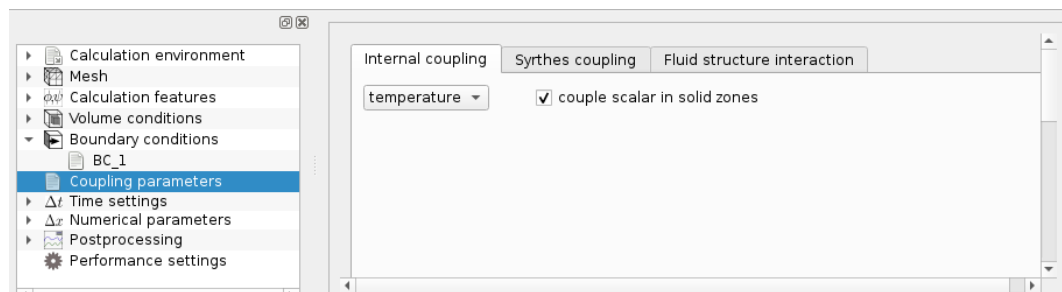

Figure 18: Conjugate heat transfer: internal coupling

3.5.3 Fluid-Thermal coupling with SYRTHES

Coupling code_saturne with SYRTHES for conjugate heat transfer can be defined through the GUI or the `cs_syrthes_coupling` user function. To set such a coupling in the GUI, a thermal scalar must be selected first in the item “Thermal scalar” under the heading “Thermophysical models”. At least one wall boundary condition must be set to “SYRTHES coupling” type, and the name of the associated SYRTHES instance (i.e. base directory name of the associated solid case definition) be set, as shown in, Figure19. The “Syrthes coupling” tab will then be available in the “Coupling parameters” section (see Figure20), fo further advanced or global settings. The zones where the coupling occurs must be defined and a projection axis can be specified in case of 2D coupling.



Figure 19: Boundary conditions - coupling with SYRTHES

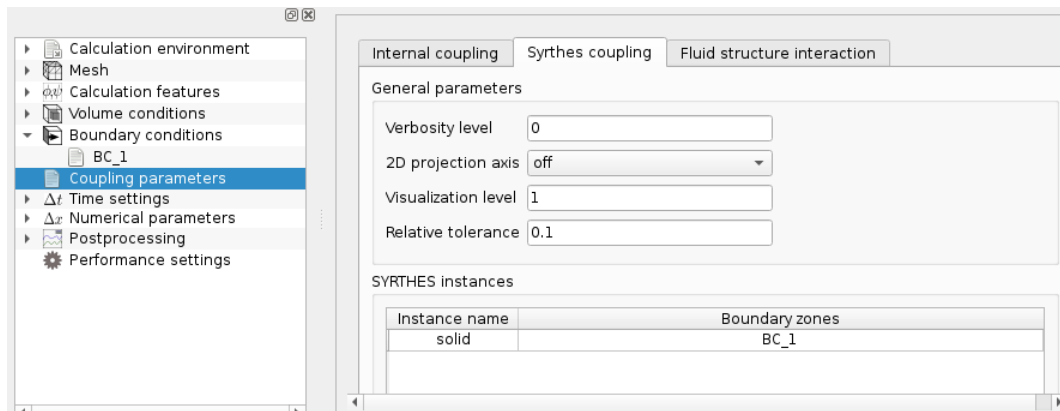

Figure 20: Coupling parameters - coupling with SYRTHES

If the function `cs_user_syrthes_coupling` is used, the user must specify the arguments passed to the `'cs_syr_coupling_define'` function. These arguments are:

- `syrthes_name` is the matching SYRTHES application name (useful only when more than one SYRTHES and one code_saturne domain are present),
- `boundary_criteria` is the surface selection criteria,
- `volume_criteria` is the volume selection criteria,
- `projection_axis`: ' ' if the user wishes to use a 3D standard coupling, or specify 'x', 'y', or 'z' as the projection axis if a 2D coupling with SYRTHES is used,
- `verbosity` is the verbosity level.

EDF R&D	code_saturne version 7.1 practical user's guide	code_saturne documentation Page 36/71
---------	--	---

- `visualization` is the visualization level.

Examples are provided in `cs_user_coupling.c`.

The user may also define global coupling options relative to the handling of time-stepping, by adapting the example `cs_user_coupling` in the `cs_user_coupling.c` file. In the case of multiple couplings, these options are global to all SYRTHES and code_saturne couplings.

3.6 Particle-tracking (Lagrangian) Module

3.6.1 General information

- The particle-tracking (or Lagrangian) module enables the simulation of poly-dispersed particulate flows, by calculating the trajectories of individual particles, mainly characterized by their diameter and density (if no heat nor mass transfer between particle and fluid are activated).
- The standard use of the particle-tracking module follows the **Moments/PDF approach**: the instantaneous properties of the underlying flow needed to calculate the particle motion are reconstructed from the averaged values (obtained by Reynolds-Averaged Navier-Stokes simulation) by using stochastic processes. The statistics of interest are then obtained through Monte-Carlo simulation.
- As a consequence, it is important to emphasize that the most important (and physically meaningful) results of a particle-tracking calculation following the Moments/PDF approach are **statistics**. Volume and surface statistics, steady or unsteady, can be calculated. Individual particle trajectories (as 1D, *EnSight*-readable cases) and displacements (as *EnSight*-readable animations) can also be provided, but only for illustrative purposes.

3.6.2 Activating the particle-tracking module

The activation of the particle-tracking module is performed either:

- in the Graphical User Interface (GUI): Calculation features → Thermophysical models → Eulerian-Lagrangian multi-phase treatment → particles and droplets tracking
- or in the user function `cs_user_lagr_model`.

3.6.3 Basic guidelines for standard simulations

Except for cases in which the flow conditions depend on time, it is generally recommended to perform a first Lagrangian calculation whose aim is to reach a steady-state (i.e. to reach a time starting from which the relevant statistics do not depend on time anymore). In a second step, a calculation restart is done to calculate the statistics. When the single-phase flow is steady and the particle volume fraction is low enough to neglect the particles influence on the continuous phase behaviour, it is recommended to perform a Lagrangian calculation on a frozen field.

It is then possible to calculate steady-state volumetric statistics and to give a statistical weight higher than 1 to the particles, in order to reduce the number of simulated (“numerical”) particles to treat while keeping the right concentrations. Otherwise, when the continuous phase flow is steady, but the two-coupling coupling must be taken into consideration, it is still possible to activate steady statistics. When the continuous phase flow is unsteady, it is no longer possible to use steady statistics. To have correct statistics at every moment in the whole calculation domain, it is imperative to have an established particle seeding and it is recommended (when it is possible) not to impose statistical weights different from the unity.

Finally, when the so-called complete model is used for turbulent dispersion modelling, the user must make sure that the volumetric statistics are directly used for the calculation of the locally undisturbed fluid flow field.

When the thermal evolution of the particles is activated, the associated particulate scalars are always the inclusion temperature and the locally undisturbed fluid flow temperature expressed in degrees Celsius, whatever the thermal scalar associated with the continuous phase is (*i.e.* temperature or enthalpy). If the thermal scalar associated with the continuous phase is the temperature in Kelvin, the unit is converted automatically into Celsius. If the thermal scalar associated with the continuous phase is the enthalpy, a `temperature` property or postprocessing field must be defined. In all cases, the thermal backward coupling of the dispersed phase on the continuous phase is adapted to the thermal scalar transported by the fluid.

3.6.4 Prescribing the main modelling parameters

USE OF THE GUI

In the GUI, the selection of the Lagrangian module activates the heading **Particle and droplets tracking** in the tree menu. The initialization is performed in the three items included in this heading:

- **Global settings.** The user defines in this item the kind of Euler/Lagrange multi-phase treatment, the main parameters, and the specific physics associated with the particles, see Figure 21 to Figure??.
- **Statistics.** The user can select the volume and boundary statistics to be post-processed.
- **Output.** An additional entry in the postprocessing section allows defining the output frequency and post-processing options for particles and selecting the variables that will appear in the log.

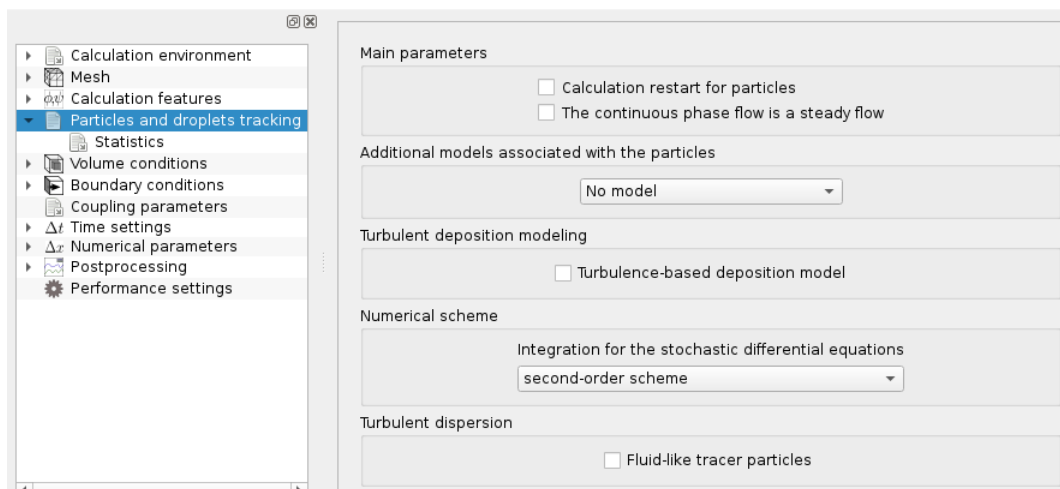

Figure 21: Lagrangian module - View of the Global Settings page

USE OF THE SUBROUTINE `CS_USER_LAGR_MODEL`

When the GUI is not used, `cs_user_lagr_model` must be completed. This function gathers in different headings all the keywords which are necessary to configure the Lagrangian module. The different headings refer to:

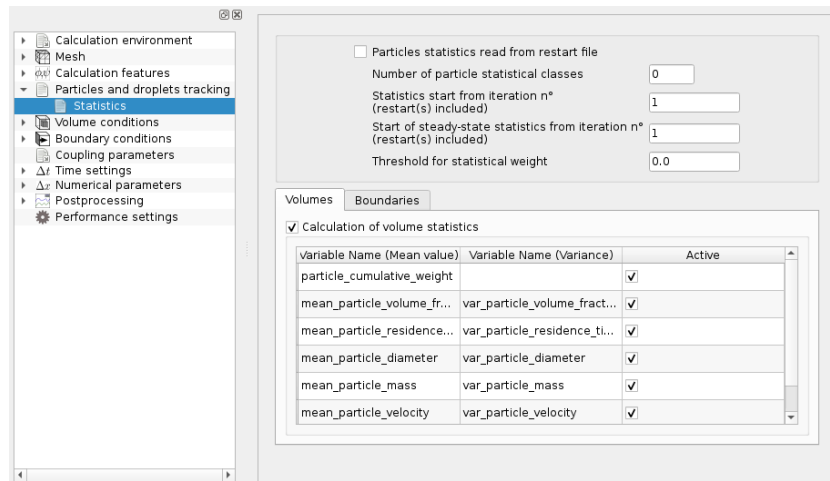

Figure 22: Lagrangian module - statistics

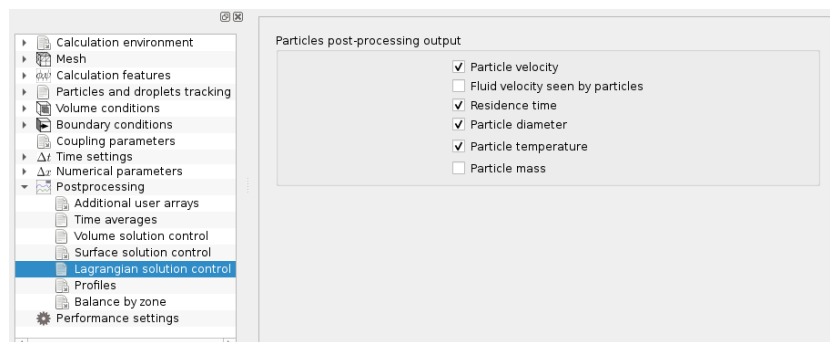

Figure 23: Lagrangian module - output

- the global configuration parameters
- the specific physical models describing the particle behaviour
- the backward coupling (influence of the dispersed phase on the continuous phase)
- the numerical parameters
- the volumetric statistics
- the boundary statistics

For more details about the different parameters, the user may refer to the keyword list (§ ??).

3.6.5 Prescribing particle boundary conditions

In the framework of the multiphase Lagrangian modelling, the management of the boundary conditions concerns the particle behaviour when there is an interaction between its trajectory and a boundary face. These boundary conditions may be imposed independently of those concerning the Eulerian fluid phase (but they are of course generally consistent). The boundary condition zones are actually redefined by the Lagrangian module (cf. §??), and a type of particle behaviour is associated with each one. The boundary conditions related to particles can be defined in the Graphical User Interface

(GUI) or in the `cs_user_lagr_boundary_conditions.c` file. More advanced user-defined boundary conditions can be prescribed in the `cs_user_lagr_in` function from `cs_user_lagr_particle.c`.

USE OF THE GUI

In the GUI, selecting the Lagrangian module in the activates the item **Particle boundary conditions** under the heading **Boundary conditions** in the tree menu. Different options are available depending on the type of standard boundary conditions selected (wall, inlet/outlet, etc...), see Figure 24.

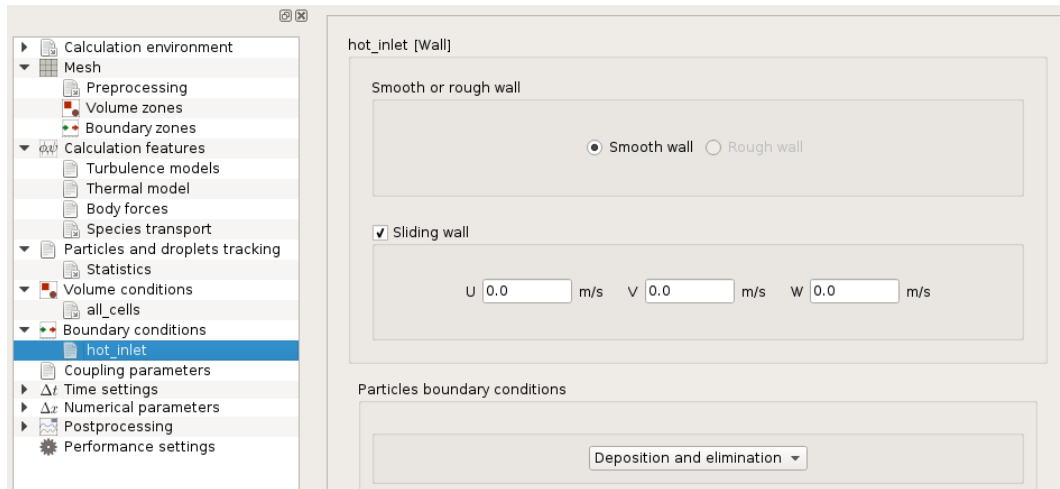

Figure 24: Lagrangian module - boundary conditions

3.6.6 Advanced particle-tracking set-up

In this section, some information is provided for a more advanced numerical set-up of a particle-tracking simulation.

USER-DEFINED STOCHASTIC DIFFERENTIAL EQUATIONS

An adaptation in the `cs_user_lagr_sde` function is required if supplementary user variables are added to the particle state vector. This function is called at each Lagrangian sub-step.

The integration of the stochastic differential equations associated with supplementary particulate variables is done in this function.

When the integration scheme of the stochastic differential equations is a first-order (`nordre = 1`), this subroutine is called once every Lagrangian iteration, if it is a second-order (`nordre = 2`), it is called twice.

The solved stochastic differential equations must be written in the form:

$$\frac{d\Phi_p}{dt} = -\frac{\Phi_p - \Pi}{\tau_\phi}$$

where Φ_p is the I th supplementary user variable, τ_ϕ is a quantity homogeneous to a characteristic time, and Π is a coefficient which may be expressed as a function of the other particulate variables.

In order to do the integration of this equation, the following parameters must be provided:

EDF R&D	code_saturne version 7.1 practical user's guide	code_saturne documentation Page 40/71
---------	--	---

- τ_ϕ , equation characteristic time every particle,
- Π , equation coefficient. If the integration scheme is a first-order, then Π is expressed as a function of the particulate variables at the previous iteration, stored in the array `eptpa`. If the chosen scheme is a second-order, then Π is expressed at the first call of the function (prediction step) as a function of the variables at the previous iteration, then at the second call (correction step) as a function of the predicted variables.

If necessary, the thermal characteristic time τ_c , whose calculation can be modified by the user in the function `cs_user_lagr_rt`.

USER-DEFINED PARTICLE RELAXATION TIME

The particle relaxation time may be modified in the `cs_user_lagr_rt` function according to the chosen formulation of the drag coefficient. The particle relaxation time, modified or not by the user, is available in the array `taup`.

USER-DEFINED PARTICLE THERMAL CHARACTERISTIC TIME

The particle thermal characteristic time may be modified in the `cs_user_lagr_rt_t` function according to the chosen correlation for the calculation of the Nusselt number. This function is called at each Lagrangian sub-step.

3.7 Compressible module

When the compressible module⁴ is activated, it is recommended to:

- use the option “time step variable in time and uniform in space” (`idtvar=1`) with a maximum Courant number of 0.4 (`coumax=0.4`): these choices must be written in `cs_user_parameters.f90` or specified with the GUI.
- keep the convective numerical schemes proposed by default (*i.e.*: upwind scheme).

With the compressible algorithm, the specific total energy is a new solved variable `isca(ienerg)`. The temperature variable deduced from the specific total energy variable is `isca(itempk)` for the compressible module.

Initialisation of the options of the variables, boundary conditions, initialisation of the variables and management of variable physical properties can be done with the GUI. We describe below the subroutines the user has to fill in without the GUI.

3.7.1 Initialisation of the options of the variables

Subroutines called at each time step.

When the GUI is not being used, the subroutines `uscfx1` and `uscfx2` in `cs_user_parameters.f90` must be completed by the user.

`uscfx1` allows to specify:

- `ieos`: equation of state (only perfect gas with a constant adiabatic coefficient, `ieos=1` is available, but the user can complete the subroutine `cs_cf_thermo`, which is not a user subroutine, to add new equations of state).

⁴For more details concerning the compressible version, the user may refer to the theory guide [10] and the document “Implantation d’un algorithme compressible dans code_saturne”, Rapport EDF 2003, HI-83/03/016/A, P. Mathon, F. Archambeau et J.-M. Hérard.

EDF R&D	code_saturne version 7.1 practical user's guide	code_saturne documentation Page 41/71
---------	--	---

- call `field_set_key_int(ivarfl(isca(itempk)), kivisl, ...)`: molecular thermal conductivity, constant (-1) or variable (0).
- `iviscv`: volumetric molecular viscosity, constant (0) or variable (1).

`uscfx2` allows to specify:

- `ivivar`: molecular viscosity, constant (0) or variable (1).
- `field_set_key_double(icavr(isca(itempk)), kvisl0, ...)`: reference molecular thermal conductivity.
- `viscv0`: reference volumetric molecular viscosity.
- `xmasmr`: molar mass of the perfect gas (`ieos=1`).
- `icfgrp`: specify if the hydrostatic equilibrium must be accounted for in the boundary conditions.

3.7.2 Management of the boundary conditions

Subroutine called at each time step.

When running the compressible module without a GUI, the `cs_user_boundary_conditions` subroutine can be used to define specific boundary conditions (see the `cs_user_boundary_conditions-compressible` file in the directory `EXAMPLES` for examples of boundary conditions with the compressible module).

With the compressible module, the following types of boundary condition are available:

- Inlet/outlet for which velocity and two thermodynamics variables are known.
- Subsonic inlet with imposed total pressure and total energy.
- Subsonic outlet with imposed static pressure.
- Supersonic outlet.
- Wall (adiabatic or not).
- Symmetry.

It is advised to only use these predefined boundary conditions type for the compressible module.

3.7.3 Initialisation of the variables

Subroutine called only at the initialisation of the calculation

When the GUI is not used, the subroutine `cs_user_initialization` is used initialize the velocity, turbulence and passive scalars (see the `cs_user_initialization-compressible` file in the directory `EXAMPLES` for examples of initialisations with the compressible module). Concerning pressure, density, temperature and specific total energy, only 2 variables out of these 4 are independent. The user may then initialise the desired variable pair (apart from temperature-energy) and the two other variables will be calculated automatically by giving the right value to the variable `ithvar` used for the call to the `cs_cf_thermo` routine.

EDF R&D	code_saturne version 7.1 practical user's guide	code_saturne documentation Page 42/71
---------	--	---

3.7.4 Management of variable physical properties

Subroutine called at each time step.

Without the GUI, all of the laws governing the physical properties of the fluid (molecular viscosity, molecular volumetric viscosity, molecular thermal conductivity and molecular diffusivity of the user-defined scalars) can be specified in the subroutine `usphyv` of the `cs_user_physical_properties` file, which is then called at each time step. This subroutine replaces and is similar to `usphyv`.

The user should check that the defined laws are valid for the whole variation range of the variables. Moreover, as only the perfect gas with a constant adiabatic coefficient equation of state is available, it is not advised to give a law for the isobaric specific heat without modifying the equation of state in the subroutine `cs_cf_thermo` which is not a user subroutine.

3.8 Management of the electric arcs module

3.8.1 Activating the electric arcs module

The electric arcs module is activated either:

- in the Graphical User Interface (GUI): Calculation features → Electrical models
- or in the user subroutine `usppmo`, by setting the `ielarc` or `ieljou` parameter to a non-null value.

3.8.2 Initialisation of the variables

Subroutine called only at initialisation of the calculation

The subroutine `cs_user_initialization` allows the user to initialise some of the specific physics variables prompted via `usppmo`. It is called only during the initialisation of the calculation. As usual, the user has access to many geometric variables so that the zones can be treated separately if needed.

The values of potential and its constituents are initialised if required.

It should be noted that the enthalpy is relevant.

- For the electric arcs module, the enthalpy value is taken from the temperature of reference `t0` (given in `cs_user_parameters.c`) from the temperature-enthalpy tables supplied in the data file `dp_ELE`. The user must not intervene here.
- For the Joule effect module, the value of enthalpy must be specified by the user. Examples of temperature to enthalpy conversion are given in `cs_user_physical_properties.c`. If not defined, a simple default law is used ($H = C_p T$).

3.8.3 Variable physical properties

All the laws of the variation of physical data of the fluid are written (when necessary) in the subroutine `cs_user_physical_properties`. It is called at each time step.

WARNING: For the electric module, it is here that all the physical variables are defined (including the relative cells and the eventual user scalars): `cs_user_physical_properties` is not used.

The user should ensure that the defined variation laws are valid for the whole range of variables. Particular care should be taken with non-linear laws (for example, a 3rd degree polynomial law giving negative values of density)

WARNING: In the electric module, all of the physical properties are considered as variables and are therefore stored using the `cs_field` API. `cp0`, `viscls0` and `viscl0` are not used

EDF R&D	code_saturne version 7.1 practical user's guide	code_saturne documentation Page 43/71
---------	--	---

For the Joule effect, the user is required to supply the physical properties in the subroutine. Examples are given which are to be adapted by the user. If the temperature is to be determined to calculate the physical properties, the solved variable, enthalpy must be deduced. The preferred temperature-enthalpy law should be defined (a general example is provided in (`cs_user_physical_properties`), and can be used for the initialisation of the variables in (`cs_user_initialization`)). For the electric arcs module, the physical properties are interpolated from the data file `dp_ELE` supplied by the user. Modifications are generally not necessary.

3.8.4 Boundary conditions

For the electric module, each boundary face in `cs_user_boundary_conditions` should be associated with a `izone` number ⁵(the color `icoul` for example) in order to group together all the boundary faces of the same type. In the `cs_user_boundary_conditions` report, the main change from the users point of view concerns the specification of the boundary conditions of the potential, which isn't implied by default. The Dirichlet and Neumann conditions must be imposed explicitly using `icodcl` and `rcodcl` (as would be done for the classical scalar).

Furthermore, if one wishes to slow down the power dissipation (Joule effect module) or the current (electric arcs module) from the imposed values (`puismp` and `couimp` respectively), they can be changed by the potential scalar as shown below:

- For the electric arcs, the imposed potential difference can be a fixed variable: for example, the cathode can be fixed at 0 and the potential at the anode contains the variable `dpot`. This variable is initialised in `cs_user_parameters.f90` by an estimated potential difference. If `ielcor=1` (see `cs_user_parameters.f90`), `dpot` is updated automatically during the calculation to obtain the required current.
- For the Joule effect module, `dpot` is again used with the same signification as in the electric arcs module. If `dpot` is not wanted in the setting of the boundary conditions, the variable `coejou` can be used. `coejou` is the coefficient by which the potential difference is multiplied to obtain the desired power dissipation. By default this begins at 1 and is updated automatically. If `ielcor=1` (see `cs_user_parameters.f90`), multiply the imposed potentials in `cs_user_boundary_conditions` by `coejou` at each time step to achieve the desired power dissipation.

WARNING: In the case of alternating current, attention should be paid to the values of potential imposed at the limits: the variable named "real potential" represents an effective value if the current is in single phase, and a "real part" if not.

- For the Joule studies, a complex potential is sometimes needed (`ippmod(ieljou)=2`): this is the case in particular where the current has three phases. To have access to the phase of the potential, and not just to its amplitude, the two variables must be deleted: in `code_saturne`, there are two arrays specified for this role, the real part and the imaginary part of the potential. For use in the code, these variables are named "real potential" and "imaginary potential". For an alternative sinusoidal potential Pp , the maximum value is noted as Pp_{max} , the phase is noted as ϕ , the real potential and the imaginary potential are respectively $Pp_{max} \cos\phi$ and $Pp_{max} \sin\phi$.
- For the Joule studies in which one does not have access to the phases, the real potential (imaginary part =0) will suffice (`ippmod(ieljou)=1`): this is obviously the case with continuous current, but also with single phase alternative current. In `code_saturne` there is only 1 variable for the potential, called "real potential". Pay attention to the fact that in alternate current, the "real potential" represents a effective value of potential, $\frac{1}{\sqrt{2}} Pp_{max}$ (in continuous current there is no such ambiguity).

⁵`izone` must be less than the maximum value allowed by the code, `nozzppm`. This is fixed at 2000 in `ppvar` and cannot be modified.

EDF R&D	code_saturne version 7.1 practical user's guide	code_saturne documentation Page 44/71
---------	--	---

ADDITIONS FOR TRANSFORMERS

The following additional boundary conditions must be defined for transformers:

- the intensity at each electrode
- the voltage on each terminal of transformers. To achieve it, the intensity, the rvoltage at each termin, the Rvoltage, and the total intensity of the transformer are calculated.

Finally, a test is performed to check if the offset is zero or if a boundary face is in contact with the ground.

3.8.5 Initialisation of the variable options

The subroutine `cs_user_parameters` (in `cs_user_parameters.c`) is called at each time step. It allows:

- to give the coefficient of relaxation of the density `srrom`:

$$\rho^{n+1} = srrom * \rho^n + (1 - srrom)\rho^n$$
(for the electric arcs, the sub-relaxation is taken into account during the 2nd time step);
- to indicate if the data will be fixed in the power dissipation or in the current, done in `ielcor`.
- target either the current fixed as `couimp` (electric arcs module) or the power dissipation `puism` (Joule module effect).
- to fix the initial value of potential difference `dpot`, the for the calculations with a single fixed parameter as `couimp` or `puism`.
- to define type of scaling model for electric arcs `modrec`. If scaling by a resetting plane is choosen then `idreca` defines the current density component and `crit_reca` the plane used for resetting of electromagnetic variables.

3.9 code_saturne-code_saturne coupling

Subroutine called once during the calculation initialisation.

The user function `cs_user_saturne_coupling` (in `cs_user_coupling.c`) is used to couple code_saturne with itself. It is used for turbo-machine applications for instance, the first code_saturne managing the fluid around the rotor and the other the fluid around the stator. In the case of a coupling between two code_saturne instances, first argument `saturne_name` of the function '`cs_sat_coupling_define`' is ignored. In case of multiple couplings, a coupling will be matched with available code_saturne instances based on that argument, which should match the directory name for the given coupled domain..

The arguments of '`cs_sat_coupling_define`' are:

- `saturne_name`: the matching code_saturne application name,
- `volume_sup_criteria`: the cell selection criteria for support,
- `boundary_sup_criteria`: the boundary face selection criteria for support (not functional),
- `volume_cpl_criteria`: the cell selection criteria for coupled cells,
- `boundary_cpl_criteria`: the boundary face selection criteria for coupled faces,
- `verbosity`: the verbosity level.

3.10 Fluid-Structure external coupling

Subroutine called only once

The subroutine `usaste` belongs to the module dedicated to external Fluid-Structure coupling with `Code_Aster`. Here one defines the boundary faces coupled with `Code_Aster` and the fluid forces components which are given to structural calculation. When using external coupling with `Code_Aster`, structure numbers necessarily need to be negative; the references of coupled faces being i.e. -1, -2, etc. The subroutine performs the following operations:

- '`getfbr`' is called to get a list of elements matching a geometrical criterion or reference number then a structure number (negative value) is associated to these elements.
- the value passed to `asddlf`, for user-chosen component, for every negative structure number, defines the movement imposed to the external structure.

3.11 ALE module

3.11.1 Initialisation of the options

This initialisation can be performed in the Graphical User Interface (GUI) or in the subroutines `usipph` and `usstr1`. Firstly, when the “Mobile mesh” is selected in GUI under the “Calculation features” heading, additional options are displayed. The user must choose the type of mesh viscosity and describe its spatial distribution, see Figure 25. The following paragraphs are relevant if the GUI

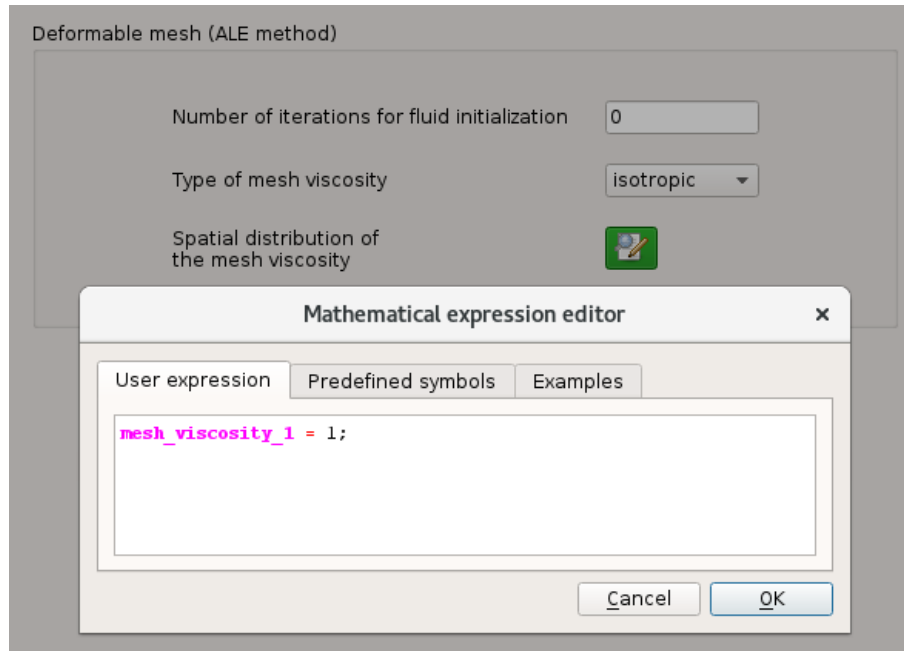

Figure 25: Thermophysical models - mobile mesh (ALE method)

is not used.

SUBROUTINE USIPPH

Subroutine called at the beginning. This subroutine completes `cs_user_parameters.f90`.

`usipph` allows setting options for the ALE module, and in particular to activate the ALE module (`iale=1`).

SUBROUTINE USSTR1

This subroutine reads in `cs_user_fluid_structure_interaction.f90`. It allows to specify the following pieces of information for the structure module:

- the index of the structure, (`idfstr(ifac)` where `ifac` is the index of the face). Then the total number of structures `nbstru` is automatically computed by the code. Be careful, the value must belong to 1, ..., `nbstru`.
- the initial value of displacement, velocity and acceleration (`xstr0`, `xstreq` and `vstr0`).

Below is a list of the different variables that might be modified:

- `idfstr(ifac)`
the index of the structure, (`idfstr(ifac)` where `ifac` is the index of the face), 0 if the face is not coupled to any structure.
- `xstr0(i,k)`
initial position of a structure, where `i` is the dimension of space and `k` the index of the structure
- `xstreq(i,k)`
equilibrium position of a structure, where `i` is the dimension of space and `k` the index of the structure
- `vstr0(i,k)`
initial velocity of a structure, where `i` is the dimension of space and `k` the index of the structure

3.11.2 Mesh velocity boundary conditions

These boundary conditions can be managed through the Graphical User Interface (GUI) or using the subroutine `usalcl` (called at each time step). With the GUI, when the item “Mobile mesh” is activated the item “Fluid structure interaction” appears under the heading “Boundary conditions”. Two types of fluid-structure coupling are offered. The first one is internal, using a simplified structure model and the second is external with *Code_Aster*, see Figure 26 and Figure 27.

SUBROUTINE USALCL

When the GUI is not used, the use of `usalcl` is mandatory to run a calculation using the ale module just as it is in `cs_user_parameters.f90`. It is used the same way as `cs_user_boundary_conditions` in the framework of standard calculations, that is to say a loop on the boundary faces marked out by their colour (or more generally by a property of their family), where the type of mesh velocity boundary condition is defined for each variable.

The main numerical variables are described below.

`ialtyb(nfabor)` [ia]: In the ale module, the user defines the mesh velocity from the colour of the boundary faces, or more generally from their properties (colours, groups, ...), from the boundary conditions defined in `cs_user_boundary_conditions`, or even from their coordinates. To do so, the array `ialtyb(nfabor)` gives for each face `ifac` the mesh velocity boundary condition types marked out by the key words `ivimpo`, `igliss`, `ibfixe` or `ifresf`.

- If `ialtyb(ifac) = ivimpo`: imposed velocity.
 - In the cases where all the nodes of a face have a imposed displacement, it is not necessary to fill the tables with mesh velocity boundary conditions for this face, these will be erased. In the other case, the value of the Dirichlet must be given in `rcodcl(ifac,ivar,1)` for every value of `ivar` (`iuma`, `ivma` and `iwma`). The other boxes of `rcodcl` and `icodcl` are completed automatically.
 - The tangential mesh velocity is taken like a tape speed under the boundary conditions of wall for the fluid, except if wall fluid velocity was specified by the user in the interface or `cs_user_boundary_conditions` (in which case it is this speed which is considered).
- if `ialtyb(ifac) = ibfixe`: fixed wall
 - the velocity is null.
- if `ialtyb(ifac) = igliss`: sliding wall
 - symmetry boundary condition on the mesh velocity vector, which means a homogeneous Neumann on the tangential mesh velocity and a zero Dirichlet on the normal mesh velocity.
- if `ialtyb(ifac) = ifresf`: free-surface

→ an imposed mesh velocity such that the fluid mass flux is equal to the mesh displacement in order to mimic the free-surface automatically. Note that the boundary condition on the fluid velocity must be set separately (homogeneous Neumann condition for instance).

3.11.3 Modification of the mesh viscosity

The user subroutine `cs_user_physical_properties` can be used along the ALE (Arbitrary Lagrangian Eulerian Method) module, and allows modifying the mesh viscosity. It is called before the time loop, and before reading restart files (so the mesh is always in its initial position at this stage). The user can modify mesh viscosity values to prevent cells and nodes from huge displacements in awkward areas, such as boundary layer for example.

Note that for more complex settings, the mesh viscosity could be modified in `cs_user_initialization` or `cs_user_extra_operations`. The matching field's name is `mesh.viscosity`.

3.11.4 Fluid - Structure internal coupling

In the subroutine `cs_user_fluid_structure_interaction` the user provides the parameters of two other subroutines. `usstr1` is called at the beginning of the calculation. It is used to define and initialise the internal structures where fluid-Structure coupling occurs. For each boundary face `ifac`, `idfstr(ifac)` is the index of the structure the face belongs to (if `idfstr(ifac) = 0`, the face `ifac` doesn't belong to any structure). When using internal coupling, structure index necessarily must be strictly positive and smaller than the number of structures. The number of "internal" structures is automatically defined with the maximum value of the `idfstr` table, meaning that internal structure numbers must be defined sequentially with positive values, beginning with integer value '1'.

For each internal structure the user can define:

- an initial velocity `vstr0`
- an initial displacement `xstr0` (*i.e.* `xstr0` is the value of the displacement `xstr` compared to the initial mesh at time $t = 0$)
- a displacement compared to equilibrium `xstreq` (*i.e.* `xstreq` is the initial displacement of the internal structure compared to its position at equilibrium; at each time step t and for a displacement `xstr(t)`, the associated internal structure will undergo a force $-k * (t + XSTREQ)$ due to the spring).

`xstr0` and `vstr0` are initialised with the value 0. When starting a calculation using ALE, or re-starting a calculation with ALE, based on a first calculation without ALE, an initial iteration 0 is automatically performed in order to take initial arrays `xstr0`, `vstr0` and `xstreq` into account. In any other case, add the following expression `'italin=1'` in subroutine `usipsu`, so that the code can deal with the arrays `xstr0`, `vstr0` and `xstreq`.

When `ihistr` is set to 1, the code writes in the output the history of the displacement, of the structural velocity, of the structural acceleration and of the fluid force. The value of structural history output step is the same as the one for standard variables `nthist`.

The second subroutine, `usstr2`, is called at each iteration. One defines in this subroutine structural parameters (considered as potentially time dependent): *i.e.*, mass `m xmstru`, friction coefficients `c xcstru`, and stiffness `k xkstru`. `forstr` array gives fluid stresses acting on each internal structure. Moreover it is also possible to take external forces (gravity for example) into account.

- . the `xstr` array indicates the displacement of the structure compared to its position in the initial mesh,
- . the `xstr0` array gives the displacement of the structures in the initial mesh compared to structural equilibrium,

EDF R&D	code_saturne version 7.1 practical user's guide	code_saturne documentation Page 49/71
---------	--	---

. the vstr array stands for structural velocity.

xstr, xstr0 and vstr are DATA tables that can be used to define the Mass, Friction and Stiffness arrays. These are not to be modified.

The 3D structural equation that is solved is the following one:

$$\underline{m}.\partial_{tt}\underline{x} + \underline{c}.\partial_t\underline{x} + \underline{k}.\left(\underline{x} + \underline{x}_0\right) = \underline{f}, \quad (4)$$

where x stands for the structural displacement compared to initial mesh position xstr, x_0 represents the displacement of the structure in initial mesh compared to equilibrium. Note that \underline{m} , \underline{c} , and \underline{k} are 3x3 matrices. Equation (4) is solved using a Newmark HHT algorithm. Note that the time step used to solve this equation, dtstr, can be different from the one of fluid calculations. The user is free to define dtstr array. At the beginning of the calculation dtstr is initialised to the value of dtcel (fluid time step).

3.12 Management of the structure property

The use of `usstr2` is mandatory to run a calculation using the ALE module with a structure module. It is called at each time step.

For each structure, the system that will be solved is:

$$M.x'' + C.x' + K.(x - x_0) = 0 \quad (5)$$

where

- M is the mass structure (`xmstru`).
- C is the damping coefficient of the structure (`xcstru`).
- K is the spring constant or force constant of the structure (`xkstru`).
- x_0 is the initial position.

Below is a list of the different variables that might be modified:

- `xmstru(i,j,k)`
mass matrix of the structure, where `i,j` is the array of mass structure and `k` the index of the structure.
- `xcstru(i,j,k)`
damping matrix coefficient of the structure, where `i,j` is the array of damping coefficient and `k` the index of the structure.
- `xkstru(i,j,k)`
spring matrix constant of the structure, where `i,j` is the array of spring constant and `k` the index of the structure.
- `forstr(i,k)`
force vector of the structure, where `i` is the force vector and `k` the index of the structure.

3.13 Management of the atmospheric module

This section describes how to set a calculation using the atmospheric module of `code_saturne`. Each paragraph describes a step of the data setting process.

3.13.1 Directory structure

The flowchart (Figure 28) recalls the directory structure of a study generated by code_saturne (see also ??). When using the atmospheric module, the structure is identical but a file called `meteo` may be added to the data settings in order to provide vertical profiles of the main variables. This file should be put in the DATA directory. For more details about the `meteo` file, see § 3.13.5).

3.13.2 The atmospheric mesh features

An atmospheric mesh has the following specific features:

- The boundary located at the top of the domain should be a plane. So, horizontal wind speed at a given altitude can be prescribed at the top face as an inlet boundary.
- Cells may have very different sizes, from very small (near ground or buildings) to very large (near the top of domain or far from zone of interest).
- Vertical resolution: from tiny cells (e.g. $\Delta z = 1$ m) near the ground to a few hundreds of meters at the top.
- Horizontal resolution: from a few meters to hundreds of meters.
- The length ratio between two adjacent cells (in each direction) should preferably be between 0.7 and 1.3.
- The z axis represents the vertical axis.

A topography map can be used to generate a mesh. In this case, the preprocessor mode is particularly useful to check the quality of the mesh (run type Mesh quality criteria).

3.13.3 Atmospheric flow model and steady/unsteady algorithm

The Graphical User Interface (GUI) may be used to enable the atmospheric flow module and set up the following calculation parameters in the Thermophysical models-Calculation features page (see Figure 29):

3.13.3.1 The atmospheric flow model

The user can choose one of the following atmospheric flow models:

- **Constant density:** To simulate neutral atmosphere.
- **Dry atmosphere:** To simulate dry, thermally-stratified atmospheric flows (enables `Potential temperature` as thermal model).
- **Humid atmosphere:** To simulate thermally stratified atmospheric flows (air-water mixture) with phase changes (enables `Liquid potential temperature` as thermal model). The model is described in Bouzereau [11].

3.13.3.2 The time algorithm

- **Steady flow algorithm:** is the one usually set. It sets a time step variable in space and time. It has to be selected if constant boundary conditions are used.
- **Unsteady flow algorithm** has to be selected for time varying boundary conditions (the time step can then be variable in time or constant).

Table Table 3.13.4 can help to choose the right parameters depending on the type of atmospheric flow.

3.13.3.3 Warnings

The following points have to be considered when setting the parameters described above:

- The potential temperature thermal model and the liquid potential temperature one (see the paragraph “Atmospheric main variables” for the definition) requires that the vertical component of the gravity is set to $g_z = -9.81m.s^{-2}$ ($g_x = g_y = 0m.s^{-2}$), otherwise pressure and density won't be correctly computed.
- As well, the use of scalar with drift for atmospheric dispersion requires the gravity to be set to $g_z = -9.81$ ($g_x = g_y = 0m.s^{-2}$), even if the density is constant.

3.13.4 Physical properties

The specific heat value has to be set to the atmospheric value $C_p = 1005J/kg/K$.

Parameters	Constant density	Dry atmosphere	Humid atmosphere	Explanation
pressure boundary condition	Neumann first order	Extrapolation	Extrapolation	In case of Extrapolation , the pressure gradient is assumed (and set) constant, whereas in case of Neumann first order , the pressure gradient is assumed (and set) to zero.
Improved pressure interpolation in stratified flows	no	yes	yes	If yes, exact balance between the hydrostatic part of the pressure gradient and the gravity term ρg is numerically ensured.
Gravity (gravity is assumed aligned with the z-axis)	$g_z = 0$ or $g_z = -9.81m.s^{-2}$ (the latter is useful for scalar with drift)	$g_z = -9.81m.s^{-2}$	$g_z = -9.81m.s^{-2}$	
Thermal variable	no	potential temperature	liquid potential temperature	
Others variables	no	no	total water content, droplets number	

Table 4: List of parameters

3.13.5 Boundary and initial conditions

The `meteo` file can be used to define initial conditions for the different fields and to set up the inlet boundary conditions. For the velocity field, `code_saturne` can automatically detect if the boundary is an inlet boundary or an outflow boundary, according to the wind speed components given in the `meteo` file with respect to the boundary face orientation. This is often used for the lateral boundaries of the atmospheric domain, especially if the profile is evolving in time. In the case of inlet flow, the

EDF R&D	code_saturne version 7.1 practical user's guide	code_saturne documentation Page 52/71
---------	--	---

data given in the `meteo` file will be used as the input data (Dirichlet boundary condition) for velocity, temperature, humidity and turbulent variables. In the case of outflow, a Neumann boundary condition is automatically imposed (except for the pressure). The unit of temperature in the `meteo` file is the degree Celsius whereas the unit in the GUI is the kelvin.

To be taken into account, the `meteo` file has to be selected in the GUI (**Atmospheric flows** page, see Figure 31) and the check box on the side ticked. This file gives the profiles of prognostic atmospheric variables containing one or a list of time stamps. The file has to be put in the `DATA` directory. An example of file `meteo` is given in the directory `DATA/REFERENCE/`. The file format has to be strictly respected. The horizontal coordinates are not used at the present time (except when boundary conditions are based on several meteorological vertical profiles) and the vertical profiles are defined with the altitude above sea level. The highest altitude of the profile should be above the top of the simulation domain and the lowest altitude of the profile should be below or equal to the lowest level of the simulation domain. The line at the end of the `meteo` file should not be empty.

If the boundary conditions are variable in time, the vertical profiles for the different time stamps have to be written sequentially in the `meteo` file.

You can also set the profiles of atmospheric variables directly in the GUI. The following boundary conditions can be selected in the GUI:

- Inlet/Outlet is automatically calculated for lateral boundaries (e.g. North, West...) of the computational domain (see Figure 32).
- Inlet for the top of the domain (see Figure 33).
- Rough wall for building walls (see Figure 34) or for the ground (see Figure 35). The user has to enter the roughness length. In case of variable roughness length, the user has to provide the land use data and the association between the roughness length values and land use categories.

Remark: If a meteorological file is given, it is used by default to initialize the variables. If a meteorological file is not given, the user can use the standard code_saturne initial and boundary conditions set up but has to be aware that even small inconsistencies can create very large buoyancy forces and spurious circulations.

3.13.5.1 Boundary conditions based on several meteorological vertical profiles

In some cases, especially when outputs of a mesoscale model are used, you need to build input boundary conditions from several meteorological vertical wind profiles. Cressman interpolation is then used to create the boundary conditions. The following files need to be put in the `DATA` directory:

- All `meteo` files giving the different vertical profiles of prognostic variables (wind, temperature, turbulent kinetic energy and dissipation).
- A file called `imbrication_files_list.txt` which is a list of the `meteo` files used.
- A separate `meteo` file which is used for the initial conditions and to impose inlet boundary conditions for the variables for which Cressman interpolation is not used (for example: temperature, turbulent kinetic energy). This file must follow the rules indicated previously.

The following files should be put in the `SRC` directory:

- The user source file `cs_user_parameters.f90`. In this file, set the `cressman_` flag of each variable, for which the Cressman interpolation should be enabled, to `.true..`

EDF R&D	code_saturne version 7.1 practical user's guide	code_saturne documentation Page 53/71
---------	--	--

3.13.6 User subroutines

The user subroutines are used when the graphical user interface is not sufficient to set up the calculation. We give some examples of user file for atmospheric application:

- `cs_user_source_terms.f90`: to add a source term in the prognostic equations for forest canopy modelling, wind turbine wake modelling... See the associated [doxygen documentation for examples of use of `cs_user_source_terms.f90`](#).
- `cs_user_parameters.f90`: to activate the Cressman interpolation. For example, it is used to impose inhomogeneous boundary conditions. See the associated [doxygen documentation for examples of use of `cs_user_parameters.f90`](#).
- `cs_user_extra_operations-extract.f90`: to generate vertical profiles for post processing. See the associated [doxygen documentation for examples of use of `cs_user_extra_operations.f90`](#).
- `cs_user_boundary_conditions-atmospheric.f90`: show how to set up the boundary conditions and to put a heterogeneous roughness length... See the associated [doxygen documentation for examples of use of `cs_user_boundary_conditions.f90`](#).

Remark: If the computation is set without the GUI, other user subroutines such as the following have to be used:

- `cs_user_initialization-atmospheric.f90`: allows to initialize or modify (in case of a restarted calculation) the calculation variables and the values of the time step. See the associated [doxygen documentation for examples of use of `cs_user_initialization.f90`](#).
- `cs_user_boundary_conditions-atmospheric.f90`: allows to define all the boundary conditions. For each type of boundary condition, faces should be grouped as physical zones characterized by an arbitrary number `izone` chosen by the user. If a boundary condition is retrieved from a meteorological profile, the variable `iprofm(izone)` of the zone has to be set to 1. The vertical profiles of atmospheric variables can be described in this file.

Examples are available in the directory `SRC/EXAMPLE`.

3.13.7 Physical models

3.13.7.1 Atmospheric dispersion of pollutants

To simulate the atmospheric dispersion of pollutant, one first need to define the source(s) term(s). That is to say the location i.e. the list of cells or boundary faces, the total air flow, the emitted mass fraction of pollutant, the emission temperature and the speed with the associated turbulent parameters. The mass fraction of pollutant is simulated through a user added scalar that could be a 'scalar with drift' if wanted (aerosols for example).

The simulations can be done using 3 different methods:

1. Using a mass source term, that is added in the Navier-Stokes equations using the `cs_user_mass_source_terms.f90` user subroutine.
2. Prescribing a boundary condition code "total imposed mass flux" for some boundary faces using the `cs_user_boundary_conditions.f90` user subroutine.
3. Using a scalar source term. In this case, the air inflow is not taken into account. The user has to add an explicit part to the equations for the scalar through the `cs_user_source_terms.f90` file. This is done by selecting the cells and adding the source term `crvexp (cells)` which equals to the air flux multiplied by the mass fraction, while the implicit part `crvimp` is set to zero.

EDF R&D	code_saturne version 7.1 practical user's guide	code_saturne documentation Page 54/71
---------	--	---

The first method is recommended, but one must take care that each source influences the dispersion of the others, which is physically realistic. So if the impact of several sources has to be analyzed independently it has first to be verified that these influences are negligible or as many simulations as there are sources have to be run.

With the second method, the same problem of sources interactions appears, and moreover standard Dirichlet conditions should not be used (use `itypfb=i_convective_inlet` and `icodcl=13` instead) as the exact emission rate cannot be prescribed because the diffusive part (usually negligible) cannot be quantified. Additionally, it requires that the boundary faces of the emission are explicitly represented in the mesh.

Finally the third method does not take into account the jet effect of the emission and so must be used only if it is sure that the emission does not modify the flow.

Whatever solution is chosen, the mass conservation should be verified by using for example the `cs_user_extra_operations-scalar_balance_by_zone.f90` file.

3.13.7.2 Soil/atmosphere interaction model

This model is based on the force restore model (Deardorff [13]). It takes into account heat and humidity exchanges between the ground and the atmosphere at daily scale and the time evolution of ground surface temperature and humidity. Surface temperature is calculated with a prognostic equation whereas a 2-layers model is used to compute surface humidity.

The parameter `iatsoil` in the file `atini0.f90` needs to be equal to one to activate the model. Then, the source file `solvar.f90` is used.

Three variables need to be initialized in the file `atini0.f90`: deep soil temperature, surface temperature and humidity.

The user needs to give the values of the model constants in the file `solcat.f90`: roughness length, albedo, emissivity...

In case of a 3D simulation domain, land use data has to be provided for the domain. Values of model constants for the land use categories have also to be provided.

3.13.7.3 Radiative model (1D)

The 1D-radiative model calculates the radiative exchange between different atmospheric layers and the surface radiative fluxes.

The radiative exchange is computed separately for two wave lengths intervals

- Calculation in the infrared spectral domain (file `rayir.f90`)
- Calculation in the spectral range of solar radiation (file `rayso.f90`)

This 1D-radiative model is needed if the soil/atmosphere interaction model is activated.

This model is activated if the parameter `iatra1` is equal to one in the file `cs_users_parameters.f90`.

3.13.8 Atmospheric main variables

For more details on the topic of atmospheric boundary layers, see Stull [12].

- Definition of the potential temperature:

$$\theta = T \left(\frac{P}{P_r} \right)^{-\frac{R_d}{C_p}}$$

- Definition of liquid potential temperature:

$$\theta_l = \theta \left(1 - \frac{L}{C_p T} q_l \right)$$

- Definition of virtual temperature:

$$T_v = (1 + 0.61q) T$$

- Gas law:

$$P = \rho \frac{R}{M_d} (1 + 0.61q) T$$

with $R = R_d M_d$.

- Hydrostatic state:

$$\frac{\partial P}{\partial z} = -\rho g$$

Constant name	Symbol	Values	Unit
Gravity acceleration at sea level	g	9.81	$m.s^{-2}$
Effective Molecular Mass for dry air	M_d	28.97	$kg.kmol^{-1}$
Standard reference pressure	P_r	10^5	Pa
Universal gas constant	R	8.3143	$J.K^{-1}.mol$
Gas constant for dry air	R_d	287	$J.kg^{-1}.K^{-1}$

Table 5: Constant name

Variable name	Symbol
Specific heat capacity of dry air	C_p
Atmospheric pressure	P
Specific humidity	q
Specific content for liquid water	q_l
Temperature	T
Virtual temperature	T_v
Potential temperature	θ
Liquid potential temperature	θ_l
Latent heat of vaporization	L
Density	ρ
Altitude	z

Table 6: Variable name

3.13.9 Recommendations

This part is a list of recommendations for atmospheric numerical simulations.

- Enough probes at different vertical levels in the domain should be used to check the convergence of the calculation.
- An inflow boundary condition at the top level of the domain should be set (symmetry and automatic inlet/outlet are not appropriate).

- A Courant number too small or too big has to be avoided (see code_saturne Best Practice Guidelines). That is the reason why the option `variable time step in space and in time` is recommended for steady simulations when there are large differences of cell size inside the domain (which is generally the case for atmospheric simulations). With this option, it can be necessary to change the reference time step and the time step maximal increase (by default, the time step increase rate is 10%).

In some cases, results can be improved with the following modifications:

- In some case, the turbulent eddy viscosity can drop to unrealistically low values (especially with $k - \varepsilon$ model in stable atmospheric condition). In those cases, it is suggested to put an artificial molecular viscosity around $0.1m^2.s^{-1}$.
- If the main direction of wind is parallel to the boundary of your computing domain, try to set symmetry boundary conditions for the lateral boundaries to avoid inflow and outflow on the same boundary zone (side of your domain). Another possibility is to use a cylindrical mesh.
- To avoid inflow and outflow on the same boundary zone (side of your domain), avoid the case of vertical profile in the input data `meteo` file with changes of the sign of velocity of wind (V_x or/and V_y).

3.14 Turbomachinery computations

3.14.1 Introduction

Two classical models are available in code_saturne for rotor/stator interactions modelling in turbomachinery computations: the steady approach which is based on the so-called *Frozen Rotor* modelling and the *transient rotor/stator* approach which is based on a sliding mesh technique.

Warning: This section describes these functionalities based on a single code_saturne computation. An alternative rotor/stator coupling based on coupling of boundary conditions is also possible (and only briefly described in this section) but it is not recommended.

3.14.2 Meshing recommendations

Periodicity The rotational periodicity treatment is possible only in *Frozen Rotor*. However, the interface plane between rotor and stator must match in the azimuthal θ direction:

$$\theta_{\min}^{\text{rotor}}(z) = \theta_{\min}^{\text{stator}}(z), \quad \theta_{\max}^{\text{rotor}}(z) = \theta_{\max}^{\text{stator}}(z)$$

for all z through the rotation axis direction.

Rotor/stator interface

- *Unsteady rotor/stator:* in the input mesh(es), the interface between rotor and stator domains has to be composed of boundary faces. Then the interface boundary faces are joined during the computation and become internal faces, as is usual for mesh joining in the preprocessing stage. A simple way to ensure joining is not done prematurely is to provide separated meshes for each rotor or stator domain.
- *Frozen Rotor:* the interface can be composed of boundary faces (in which case the interface boundary faces are joined at the beginning of the computation) or of internal faces.

EDF R&D	code_saturne version 7.1 practical user's guide	code_saturne documentation Page 57/71
---------	---	--

Meshing of the interface region As mentioned above, when a rotor/stator interface boundary exists (in particular for the *unsteady rotor/stator* model), boundary faces are joined by the solver during the computation, based on the current rotor position. It is thus important to be aware that the success of a joining operation is strongly dependant on the quality of the mesh at the interface. More precisely, the refinement must be as similar as possible at both sides of the interface. Moreover, it is reminded that the tolerance parameter of a joining is a fraction of the shortest edge linked with a vertex of a joined face. Consequently, cells with high aspect ratios where the refinement in the azimuthal θ direction is much coarser than those in one of the two others can also lead to a joining failure. In particular, the user should be careful to avoid elongated viscous layer type cells in curved areas such as a rotor-stator interface.

If the meshes at both sides of the interface are very different such that the joining fails, advanced joining parameters are available. However, modifying the mesh is more likely to succeed. The introduction of a somekind of buffer cells layer on both sides of the interface should be very valuable. Ideally, each of the two layers should have the same refinement and a constant azimuthal step (this latter recommandation is relevant only for *unsteady rotor/stator* model).

Alternative rotor/stator coupling If the meshes at both sides of the interface are very different and can not be modified, a fallback solution is to use the rotor/stator model based on the boundary conditions coupling.

Warning: Contrarily to the mesh joining approach, the boundary conditions coupling approach is not fully conservative.

3.14.3 Turbomachinery dedicated postprocessing functions

Useful postprocessing functions relative to the machinery characteristics are available: postprocessing of the couple on the rotor walls and postprocessing of the head generated by the machinery.

3.14.4 Data setting, keywords and examples

Data setting, keywords and examples for turbomachinery computations (mesh joining or boundary conditions coupling), are provided in [the dedicated doxygen documentation](#).

3.15 Cavitation module

The cavitation module is based on an homogeneous mixture model. The physical properties (density and dynamic viscosity) of the mixture depends on a resolved void fraction and constant reference properties of the liquid phase and the gas phase.

For a description of the user management of the cavitation module, please refer to [the dedicated doxygen documentation](#).

Internal coupling with a simplified structure model External coupling with code_aster

Internal coupling

Maximum number of sub-iterations for implicit coupling with internal structures

Relative precision for implicit coupling with internal structures

Advanced options 



Structures definition

Structure number	Label	Location
------------------	-------	----------

Velocity and position

Initial position	Position of Equilibrium	Initial Velocity
X_I <input type="text"/>	X_E <input type="text"/>	V_X <input type="text"/>
Y_I <input type="text"/>	Y_E <input type="text"/>	V_Y <input type="text"/>
Z_I <input type="text"/>	Z_E <input type="text"/>	V_Z <input type="text"/>

Structure characteristics

Mass matrix  Damping matrix  Stiffness matrix 

Force applied to the structure



Figure 26: Boundary conditions - internal coupling

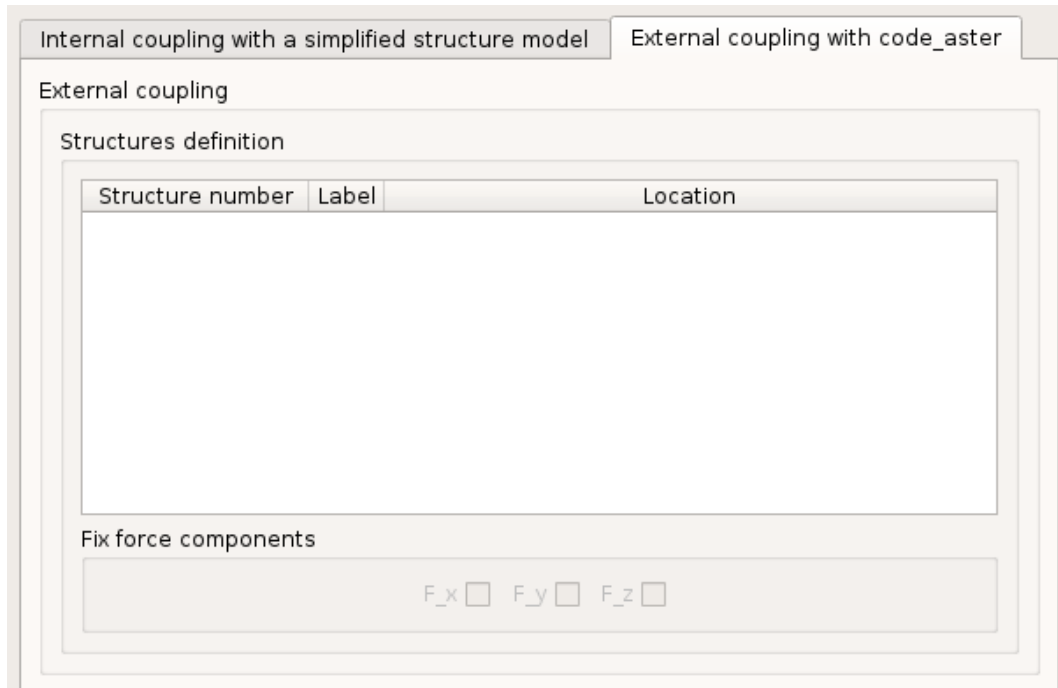

Figure 27: Boundary conditions - external coupling

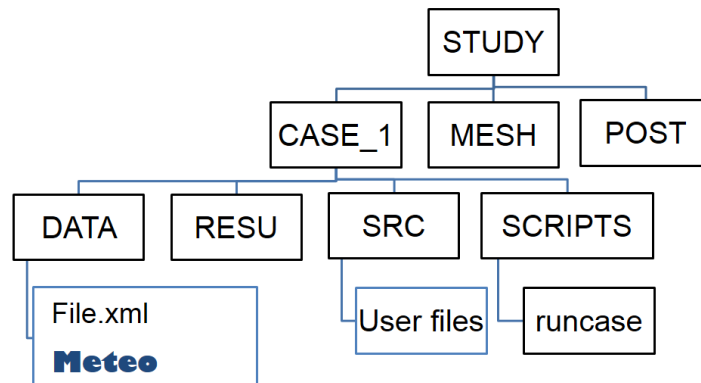

Figure 28: Organization of a study (specific files of atmospheric version in bold type)

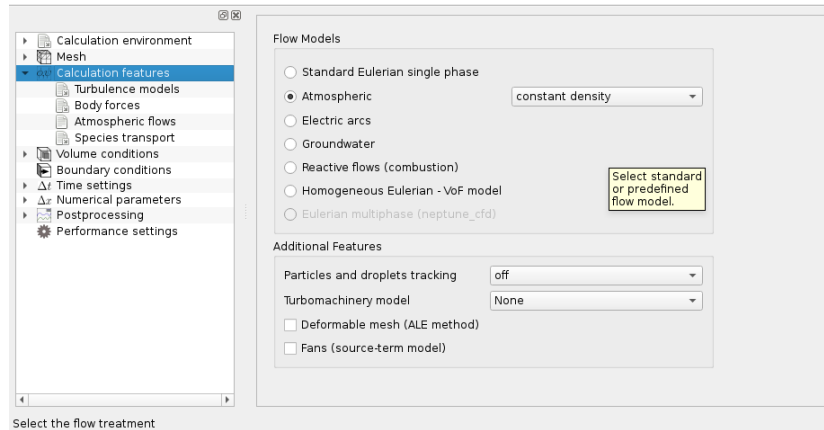

Figure 29: Selection of atmospheric model

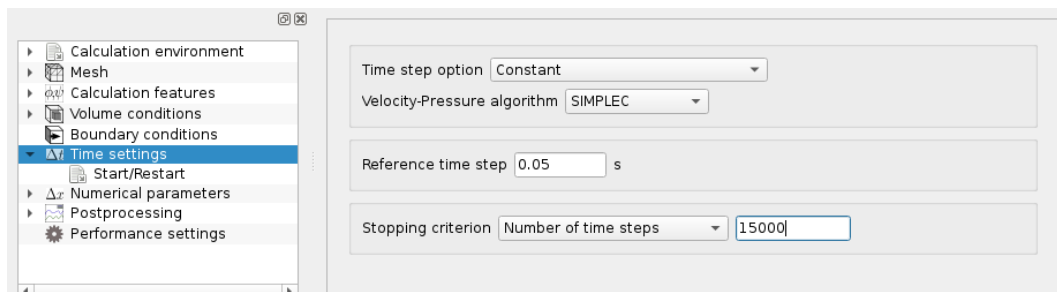

Figure 30: Selection of steady/unsteady flow algorithm

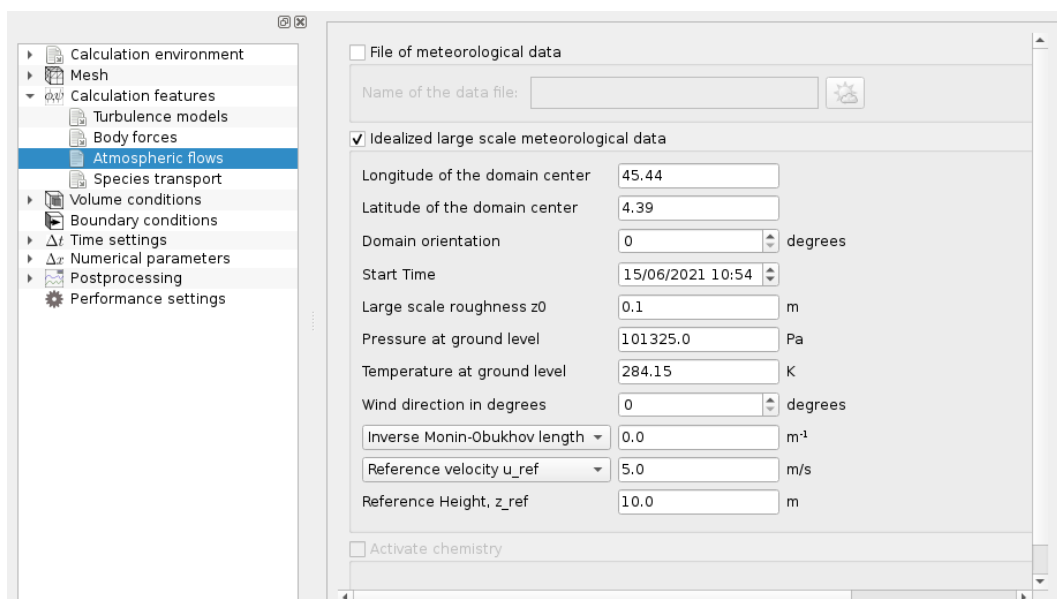

Figure 31: Selection of the meteo file

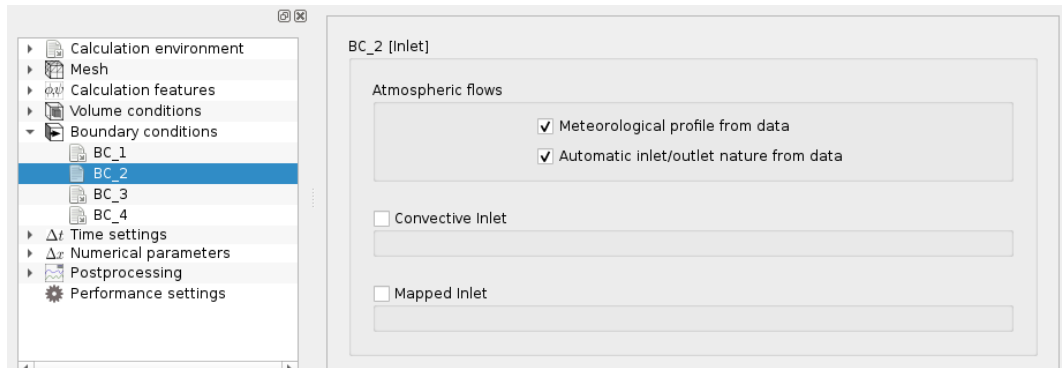

Figure 32: Selection of automatic inlet/ outlet for boundary's conditions

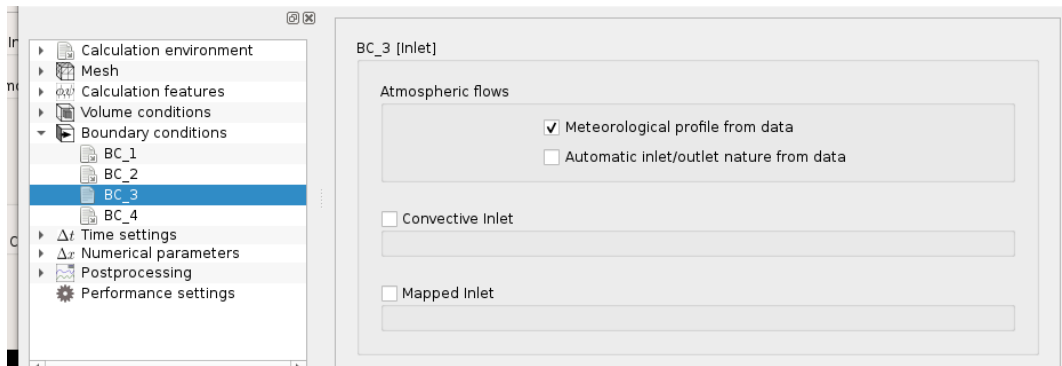

Figure 33: Selection of the boundary condition for the top of the domain

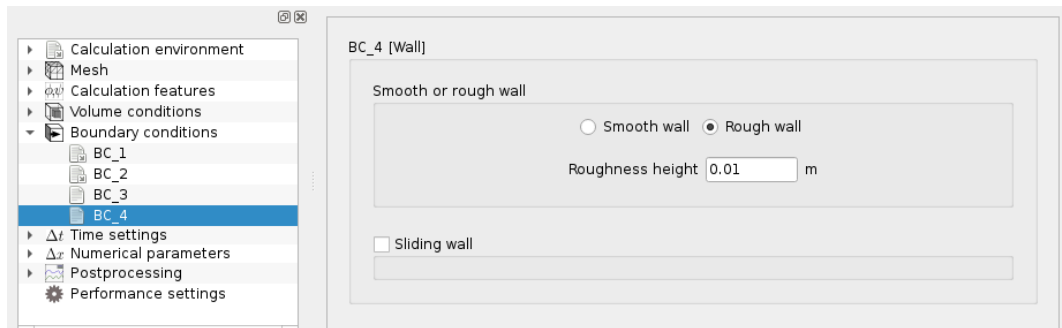

Figure 34: Selection of the boundary condition for building walls

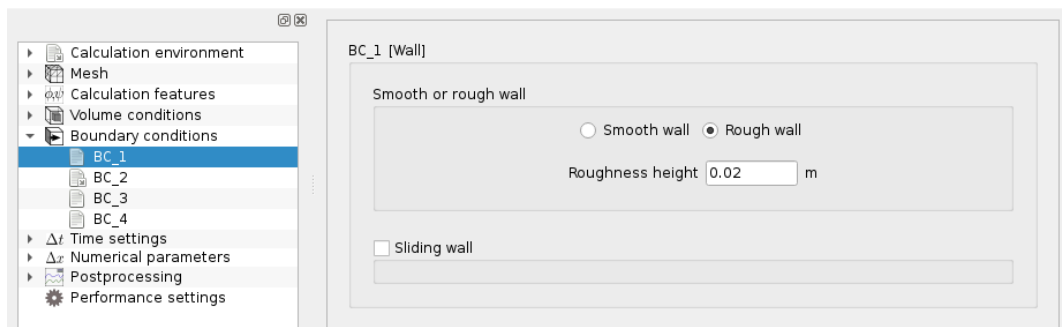

Figure 35: Selection of the boundary condition for the ground

4 Keyword list

The keywords are classified under relevant headings. For each keyword of code_saturne Kernel, the following informations are given:

Variable name	Type	Allowed values	[Default]	O/C	Level
	Description				
	Potential dependences				

- **Variable name:** Name of the variable containing the keyword.
- **Type:** a (Array), i (Integer), r (Real number), c (Character string).
- **Allowed values:** list or range of allowed values.
- **Default:** value defined by the code before any user modification (every keyword has one). In some cases, a non-allowed value is given (generally -999 or -10^{12}), forcing the user to specify a value. If he does not do it, the code may:
 - automatically use a recommended value (for example, automatic choice of the variables for which chronological records will be generated).
 - stop, if the keyword is essential.
- **O/C:** Optional/Compulsory
 - O: optional keyword, whose default value may be enough.
 - C: keyword which must imperatively be specified.
- **Level:** L1, L2 or L3
 - L1 (level 1): the users will have to modify it in the framework of standard applications. The L1 keywords are written in bold.
 - L2 (level 2): the users may have to modify it in the framework of advanced applications. The L2 keywords are all optional.
 - L3 (level 3): the developers may have to modify it; it keeps its default value in any other case. The L3 keywords are all optional.
- **Description:** keyword description, with its potential dependences.

The L1 keywords can be modified through the Graphical Use Interface or in the `cs_user_parameters.c` file. L2 and L3 keywords can only be modified through the `cs_user_parameters.c` file, even if they do not appear in the version proposed as example in the `SRC/REFERENCE/base` directory. It is however recommended not to modify the keywords which do not belong to the L1 level.

The alphabetical keyword list is displayed in the index, in the end of this report.

NOTES

- The notation “d” refers to a double precision real. For instance, 1.8d-2 means 0.018.
- The notation “grand” (which can be used in the code) corresponds to 10^{12} .

4.1 Input-output

NOTES

- Two different files can not use the same unit number (in Fortran) nor the same name.

4.1.1 "Calculation" files

GENERAL

THERMOCHEMISTRY

For the calculation file related to the thermochemistry, please refer to the dedicated [Doxygen documentation](#).

4.2 Numerical options

4.2.1 Calculation management

The following [Doxygen documentation](#) provides information about the various calculation management options available in code_saturne such as `ntmabs`, `ntcabs`, etc.

4.2.2 Scalar unknowns

Several keywords referring to the scalar unknowns are detailed in the following [Doxygen documentation](#). The [Doxygen page](#) of the Stokes model structure also contains some keywords such as `icpsyr`, `iclvf1` or `itbrrb`. For other keywords, please refer to the following [Doxygen](#) pages referring to `nscaus` and `iscacp`.

4.2.3 Definition of the equations

For informations about `istat`, `iconv`, `idiff` or `idifft`, please refer to the following [Doxygen documentation](#).

Moreover, one can find details about the `idircl` keyword [here](#) and about the `ivisse` keyword [there](#).

4.2.4 Definition of the time advancement

idilat	i	1, 2, 3, 4	[1]	O	L1
	Algorithm to take into account the density variation in time				
	= 1: steady dilatable flow algorithm (default)				
	= 2: unsteady dilatable flow algorithm				
	= 3: low-Mach number algorithm				
	= 4: non conservative algorithm for fire simulation				
	always useful				
cdtvar	ra	strictly positive real number	[1]	O	L1
	multiplicative factor applied to the time step for each scalar				
	Hence, the time step used when solving the evolution equation for the variable is the time step used for the dynamic equations (velocity/pressure) multiplied by <code>cdtvar</code> .				
	The size of the array <code>cdtvar</code> is <code>nvar</code> . For instance, the multiplicative coefficient applied to the scalar 2 is <code>cdtvar(isca(2))</code> . Yet, the value of <code>cdtvar</code> for the velocity components and the pressure is not used. Also, although it is possible to change the value of <code>cdtvar</code> for the turbulent variables, it is highly not recommended useful if and only if <code>nscal</code> \geq 1				

varrdt r strictly positive real number [0.1] O L3
maximum allowed relative increase in the calculated time step value between two successive time steps (to ensure stability, any decrease in the time step is immediate and without limit)
useful if `idtvar` $\neq 0$

For details about time stepping options, please refer to the dedicated [Doxygen documentation](#).

NON-CONSTANT TIME STEP

The calculation of the time step uses a reference time step `dtref` (at the calculation beginning). Later, every time step, the time step value is calculated by taking into account the different existing limits, in the following order:

- `coumax`, `foumax`: the more restrictive limit between both is used (in the compressible module, the acoustic limitation is added),
- `varrdt`: progressive increase and immediate decrease in the time step,
- `iptlro`: limitation by the thermal time step,
- `dtmax` and `dtmin`: clipping of the time step to the maximum, then to the minimum limit.

4.2.5 Turbulence

The $k - \varepsilon$ (standard and linearized production) and $R_{ij} - \varepsilon$ (LRR and SSG) turbulence models implemented in `code_saturne` are “High-Reynolds” models. It is therefore necessary to make sure that the thickness of the first cell neighboring the wall is larger than the thickness of the viscous sub-layer (at the wall, $y^+ > 2.5$ is required as a minimum, and preferably between 30 and 100)⁶. If the mesh does not respect this condition, the results may be biased (particularly if thermal processes are involved). Using scalable wall-functions (cf. keyword `iwallf`) may help avoiding this problem.

The $v2-f$ model is a “Low-Reynolds” model, it is therefore necessary to make sure that the thickness of the first cell neighboring the wall is smaller than the thickness of the viscous sub-layer ($y^+ < 1$).

The $k - \omega$ SST model provides correct results whatever the thickness of the first cell. Yet, it requires the knowledge of the distance to the wall in every cell of the calculation domain. The user may refer to the keyword `icdpar` for more details about the potential limitations.

The $k - \varepsilon$ model with linear production allows to correct the known flaw of the standard $k - \varepsilon$ model which overestimates the turbulence level in case of strong velocity gradients (stopping point).

With LES, the wall functions are usually not greatly adapted. It is generally more advisable (if possible) to refine the mesh towards the wall so that the first cell is in the viscous sub-layer, where the boundary conditions are simple natural no-slip conditions.

Concerning the LES model, the user may refer to the subroutine `ussmag` for complements about the dynamic model. Its usage and the interpretation of its results require particular attention. In addition, the user must pay further attention when using the dynamic model with the least squares method based on a partial extended neighbourhood (`imrga=3`). Indeed, the results may be degraded if the user does not implement his own way of averaging the dynamic constant in `ussmag` (*i.e.* if the user keeps the local average based on the extended neighbourhood).

For further details, please refer to the following [Doxygen documentation](#) dealing with [turbulence options](#) and [turbulence constants](#).

4.2.6 Time scheme

By default, the standard time scheme is a first-order. A second-order scheme is activated automatically with LES modelling. On the other hand, when “specific physics” (gas combustion, pulverised coal,

⁶While creating the mesh, $y^+ = \frac{yu^*}{\nu}$ is generally unknown. It can be roughly estimated as $\frac{yU}{10\nu}$, where U is the characteristic velocity, ν is the kinematic viscosity of the fluid and y is the mid-height of the first cell near the wall.

EDF R&D	code_saturne version 7.1 practical user's guide	code_saturne documentation Page 65/71
---------	--	---

compressible module) are activated, the second-order scheme is not allowed.

In the current version, the second-order time scheme is not compatible with the estimators (`iescal`), the velocity-pressure coupling (`ipucou`), the modelling of hydrostatic pressure (`icalhy` and `iphydr`) and the time- or space-variable time step (`idtvar`).

Also, in the case of a rotation periodicity, a proper second-order is not ensured for the velocity, but calculations remain possible.

It is recommended to keep the default values of the variables listed below. Hence, in standard cases, the user does not need to specify these options.

Please refer to the dedicated [Doxygen documentation](#) for detailed informations about the time stepping parameters.

4.2.7 Gradient reconstruction

The gradient reconstruction keywords such as `imrgra`, `nswrgr`, `epsrgr`, `imligr`, or `climgr` are members of the `cs_var_cal_opt_t` structure for which informations can be found in the following [Doxygen documentation](#).

Details on the `anomax` keyword can be found [here](#) as well.

4.2.8 Solution of the linear systems

See [the dedicated Doxygen documentation](#) for most settings related to linear solver options.

More informations on these settings can also be found [here](#).

4.2.9 Convective scheme

For informations on the keywords related to the convective scheme (i.e. `blencv`, `ischcv`, `isstpc`) please refer to the following [Doxygen documentation](#).

4.2.10 Pressure-continuity step

Several options related to the pressure-continuity step are available and can be modified by the user. These options can be found in the following [Doxygen documentation](#). For details about the porosity keyword `iporos`, please refer to the dedicated [Doxygen documentation](#).

4.2.11 Error estimators for Navier-Stokes

There are currently `nestmx=4` types of local estimators provided at every time step, with two possible definitions for each⁷. These scalars indicate the areas (cells) in which some error types may be important. They are stored using the `cs_field` API (see `field_get_val_s(iestim(iestim), c_estim)`). For each estimator, the code writes the minimum and maximum values in the log and generates post-processing outputs along with the other variables.

The additional memory cost is about one real number per cell and per estimator. The additional calculation cost is variable. For instance, on a simple test case, the total estimator `iestot` generates an additional cost of 15 to 20 % on the CPU time⁸; the cost of the three others may be neglected. If the user wants to avoid the calculation of the estimators during the computation, it is possible to run a calculation without estimators first, and then activate them on a restart of one or two time steps.

⁷Choice made by the user

⁸Indeed, all the first-order in space differential terms have to be recalculated at the time t^{n+1}

EDF R&D	code_saturne version 7.1 practical user's guide	code_saturne documentation Page 66/71
---------	--	---

It is recommended to use the estimators only for visual and qualitative analysis. Also, their use is compatible neither with a second-order time scheme nor with a calculation with a frozen velocity field.

iest = iespre: prediction (default name: EsPre). After the velocity prediction step (yielding $\tilde{\underline{u}}$), the estimator $\eta_{i,k}^{pred}(\tilde{\underline{u}})$, local variable calculated at every cell Ω_i , is created from $\underline{\mathcal{R}}^{pred}(\tilde{\underline{u}})$, which represents the residual of the equation solved during this step:

$$\begin{aligned} \underline{\mathcal{R}}^{pred}(\tilde{\underline{u}}) &= \rho^n \frac{\tilde{\underline{u}} - \underline{u}^n}{\Delta t} + \underline{\nabla}(\tilde{\underline{u}}) \cdot (\rho \underline{u})^n - \text{div}((\mu + \mu_t)^n \underline{\nabla}(\tilde{\underline{u}})) + \underline{\nabla}(P^n) \\ &- \text{rest of the right-hand side}(\underline{u}^n, P^n, \text{other variables}^n) \end{aligned}$$

By definition:

$$\eta_{i,k}^{pred}(\tilde{\underline{u}}) = |\Omega_i|^{(k-2)/2} \|\underline{\mathcal{R}}^{pred}(\tilde{\underline{u}})\|_{\mathbb{L}^2(\Omega_i)}$$

- The first family, $k = 1$, suppresses the volume $|\Omega_i|$ which intrinsically appears with the norm $\mathbb{L}^2(\Omega_i)$.
- The second family, $k = 2$, exactly represents the norm $\mathbb{L}^2(\Omega_i)$. The size of the cell therefore appears in its calculation and induces a weighting effect.

$\eta_{i,k}^{pred}(\tilde{\underline{u}})$ is ideally equal to zero when the reconstruction methods are perfect and the associated system is solved exactly.

iest = iesder: drift (default name: EsDer). The estimator $\eta_{i,k}^{der}(\underline{u}^{n+1})$ is based on the following quantity (intrinsic to the code):

$$\begin{aligned} \eta_{i,k}^{der}(\underline{u}^{n+1}) &= |\Omega_i|^{(k-2)/2} \|\text{div}(\text{corrected mass flow after the pressure step}) - \Gamma\|_{L^2(\Omega_i)} \\ &= |\Omega_i|^{(1-k)/2} |\text{div}(\text{corrected mass flow after the pressure step}) - \Gamma| \end{aligned} \quad (6)$$

Ideally, it is equal to zero when the Poisson equation related to the pressure is solved exactly.

iest = iescor: correction (default name: EsCor). The estimator $\eta_{i,k}^{corr}(\underline{u}^{n+1})$ comes directly from the mass flow calculated with the updated velocity field:

$$\eta_{i,k}^{corr}(\underline{u}^{n+1}) = |\Omega_i|^{\delta_{2,k}} |\text{div}(\rho^n \underline{u}^{n+1}) - \Gamma|$$

The velocities \underline{u}^{n+1} are taken at the cell centers, the divergence is calculated after projection on the faces.

$\delta_{2,k}$ represents the Kronecker symbol.

- The first family, $k = 1$, is the absolute raw value of the divergence of the mass flow minus the mass source term.
- The second family, $k = 2$, represents a physical property and allows to evaluate the difference in $kg.s^{-1}$.

Ideally, it is equal to zero when the Poisson equation is solved exactly and the projection from the mass flux at the faces to the velocity at the cell centers is made in a set of functions with null divergence.

iest = iestot: total (default name: EsTot). The estimator $\eta_{i,k}^{tot}(\underline{u}^{n+1})$, local variable calculated at every cell Ω_i , is based on the quantity $\underline{\mathcal{R}}^{tot}(\underline{u}^{n+1})$, which represents the residual of the equation using the updated values of \underline{u} and P :

$$\begin{aligned} \underline{\mathcal{R}}^{tot}(\underline{u}^{n+1}) &= \rho^n \frac{\underline{u}^{n+1} - \underline{u}^n}{\Delta t} + \underline{\nabla}(\underline{u}^{n+1}) \cdot (\rho \underline{u})^{n+1} - \text{div}((\mu + \mu_t)^n \underline{\nabla}(\underline{u}^{n+1})) + \underline{\nabla}(P^{n+1}) \\ &- \text{rest of the right-hand side}(\underline{u}^{n+1}, P^{n+1}, \text{other variables}^n) \end{aligned}$$

By definition:

$$\eta_{i,k}^{tot}(\underline{u}^{n+1}) = |\Omega_i|^{(k-2)/2} \|\underline{\mathcal{R}}^{tot}(\underline{u}^{n+1})\|_{\mathbb{L}^2(\Omega_i)}$$

The mass flux in the convective term is recalculated from \underline{u}^{n+1} expressed at the cell centres (and not taken from the updated mass flow at the faces).

As for the prediction estimator:

- The first family, $k = 1$, suppresses the volume $|\Omega_i|$ which intrinsically appears with the norm $\mathbb{L}^2(\Omega_i)$.
- The second family, $k = 2$, exactly represents the norm $\mathbb{L}^2(\Omega_i)$. The size of the cell therefore appears in its calculation and induces a weighting effect.

The estimators are evaluated depending on the values of `iescal`.

4.2.12 Calculation of the distance to the wall

The options related to the calculation of the distance to the wall are described in the following [Doxygen documentation](#). Some options are used only in the case of the calculation of the non-dimensional distance to the wall y^+ (LES model with van Driest damping). Most of the keywords are simple copies of the keywords for the numerical options of the general equations, with a potentially specific value in the case of the calculation of the distance to the wall.

4.2.13 Others

Informations concerning the remaining keywords can be reached through the following [Doxygen](#) pages:

- [iccvfg](#) and [ipucou](#)
- [nterup](#) and [epsup](#)
- [imvisf](#)
- [irclu](#), [nswrsm](#) and [epsrsm](#)
- [isuit1](#)

4.3 Numerical, physical and modelling parameters

4.3.1 Numeric parameters

These parameters correspond to numeric reference values in the code. They can be used but shall not be modified (they are defined as `parameter`).

For a list of these physical parameters, please refer to the following [Doxygen documentation](#).

4.3.2 Physical parameters

These parameters correspond to physical reference values in the code. They can be used but shall not be modified (they are defined as `parameter`).

For a list of these physical parameters, please refer to the following [Doxygen documentation](#).

4.3.3 Physical variables

Most physical variables are listed in the following [Doxygen documentation](#).

Other physical variables such as `dift10`, `srrom`, `sigmas` or `rvarf1` are described in the following [Doxygen](#) pages :

- [dift10](#),

EDF R&D	code_saturne version 7.1 practical user's guide	code_saturne documentation Page 68/71
---------	--	---

- [srrom](#),
- [sigmas](#), [rvarfl](#).

4.4 ALE

For further details about the ALE calculation options, please refer to the dedicated Doxygen pages [here](#) and [there](#). The following [Doxygen documentation](#) might be useful as well.

4.5 Thermal radiative transfers: global settings

Most of radiative module keywords may be modified in the user subroutines `cs_user_radiative_*` (or, for some of them, through the thermochemical data files).

For a detailed list of these keywords, please refer to the following [Doxygen documentation](#).

4.6 Electric module (Joule effect and electric arcs): specificities

The electric module is composed of a Joule effect module (`ippmod(ieljou)`) and an electric arcs module (`ippmod(ielarc)`).

The Joule effect module is designed to take into account the Joule effect (for instance in glass furnaces) with real or complex potential in the enthalpy equation. The Laplace forces are not taken into account in the impulse momentum equation. Specific boundary conditions can be applied to account for the coupled effect of transformers (offset) in glass furnaces.

The electric arcs module is designed to take into account the Joule effect (only with real potential) in the enthalpy equation. The Laplace forces are taken into account in the impulse momentum equation.

The different keywords used in the electric module are detailed in the following [Doxygen documentation](#).

5 Bibliography

- [1] F. ARCHAMBEAU, N. MÉCHITOUA, M. SAKIZ,
code_saturne: a Finite Volume Code for the Computation of Turbulent Incompressible Flows,
Industrial Applications, International Journal on Finite Volumes, Vol. 1, 2004.
- [2] S. BENHAMADOUCHE,
*Modélisation de sous-maille pour la LES - Validation avec la Turbulence Homogène Isotrope (THI)
dans une version de développement de code_saturne*,
EDF Report HI-83/01/033/A, 2001 (in French).
- [3] M. BOUCKER, J.D. MATTÉI,
*Proposition de modification des conditions aux limites de paroi turbulente pour le Solveur Commun
dans le cadre du modèle $k - \varepsilon$ standard*,
EDF Report HI-81/00/019/A, 2000 (in French).
- [4] A. ESCAICH, P. PLION, *Mise en œuvre dans code_saturne des modélisations physiques particulières.
Tome 1 : Combustion en phase gaz*,
EDF Report, HI-81/02/03/A, 2002 (in French).
- [5] A. ESCAICH, *Mise en œuvre dans code_saturne des modélisations physiques particulières. Tome 2 :
Combustion du charbon pulvérisé*,
EDF Report, HI-81/02/09/A, 2002 (in French).
- [6] A. DOUCE, N. MÉCHITOUA,
*Mise en œuvre dans code_saturne des physiques particulières. Tome3 : Transfert thermique radiatif
en milieu gris semi-transparent*,
EDF Report HI-81/02/019/A, 2002 (in French).
- [7] M. TAGORTI., S. DAL-SECCO, A. DOUCE, N. MÉCHITOUA,
*Physiques particulières dans code_saturne, tome 4 : le modèle P-1 pour la modélisation des trans-
ferts thermiques radiatifs en milieu gris semi-transparent*,
EDF Report HI-81/03/017/A, 2003 (in French).
- [8] A. DOUCE,
*Physiques particulières dans code_saturne 1.1, Tome 5 : modélisation stochastique lagrangienne
d'écoulements turbulents diphasiques polydispersés*,
EDF Report, HI-81/04/03/A, 2005 (in French).
- [9] N. MÉCHITOUA, F. ARCHAMBEAU,
*Prototype de solveur volumes finis co-localisé sur maillage non-structuré pour les équations de
Navier-Stokes 3D incompressibles et dilatables avec turbulence et scalaire passif*,
EDF Report HE-41/98/010/B, 1998 (in French).
- [10] CODE_SATURNE DOCUMENTATION,
code_saturne 7.1 Theory and Programmer's guide,
on line with the release of code_saturne 7.1 (`code_saturne info --guide theory`).
- [11] E. BOUZEREAU,
*Représentation des nuages chauds dans le modèle météorologique "Mercure": Application aux
panaches d'aéroréfrigérants et aux précipitations orographiques*,
EDF, Université Pierre et Marie Curie-Paris VI, PHD, 2004 (in French).
- [12] R. STULL,
An introduction to boundary layer meteorology ,
Springer, 1988.
- [13] J.W. DEARDORFF,
*Efficient prediction of ground surface temperature and moisture with inclusion of a layer of vege-
tation*,
Journal of Geophysical Research, 83:1889-1903 , 1978.

Index of the main variables and keywords

– Symbols –	
icodcl	9
itypfb	8
rcodcl	9
– A –	
atgaze	20
– C –	
cdtvar	63
cebu	29
ckabsg	21
compog	20
couimp	43
– D –	
diftl0	29
distch	26
– E –	
ehgazg	21
– F –	
fment	26
fs(1)	21
– I –	
i_convective_inlet	9
ialtyb	47
ibfixe	47
iccoal	18
icdpar	64
icfuel	18
ickabs	28
icod3p	17
icoebu	17, 18
icolwc	18
icompf	19
icpl3c	18
idebty	14
idiam2	28
idilat	63
ielarc	18, 68
ieljou	18, 68
ientat	26
ientcp	26
ientfu	26
ientgb	25
ientgf	25
ientox	26
ientre	9, 25
iescor	66
iesder	66
iespre	66
iestot	66
if1m	24, 29
if2m	24, 29
if3m	24, 29
if3p2m	29
if4p2m	24
if4pm	29
ifinty	14
ifm	22, 28
ifp2m	22, 28
ifp3m	24
ifrent	9
ifresf	9, 47
igfuel	20
igliss	47
igmdch	28
igmdv1	28
igmdv2	28
igmhet	28
igoxy	20
ih2	24, 28
ihm	28
iindef	9
immel	28
indjon	19
inp	24, 28
iparoi	9
iparug	9
ippmod	17
iqimp	25
irom2	28
isolib	9
isymet	9
it3m	28
it4m	28
itemp	28
itemp1	29
itemp2	28
itrifb	14
iu	25
iv	25
ivimpo	47
iw	25
ix2	28
ixch	22, 28
ixck	24, 28
ixkabe	21
iygfm	22, 28
iy(1)	28
iy(2)	28
iy(3)	28
iy(1)(1)	29

iyml(2)	29	xh2o	21
iyml(3)	29	xkabe	21
iyml(4)	29	xkabel	21
iyml(5)	29		
iyml(6)	29		
iyml(7)	29		
izone	25		
– K –			
kabse	20		
– N –			
nato	20		
ncharm	18		
nclpch	18		
ncpcmx	18		
nestmx	65		
ngaze	20		
ngazg	20, 21		
nomcoe	20		
npo	20, 21		
nrgez	20		
ntypmx	11		
– P –			
puismp	43		
– Q –			
qimp	25		
qimpat	26		
qimpcp	26		
– R –			
rcodcl	25		
– S –			
srrom	29		
stoeg	20		
– T –			
th	21		
timpat	26		
timpcp	26		
tinfue	26		
tinoxy	26		
tkent	26		
tmax	20		
tmin	20		
– V –			
varrdt	64		
– W –			
wmolat	20		
wmolg	21		
– X –			
xco2	21		